

FuelTech



FT250
FT300

Programmable Electronic Fuel
Injection and Ignition System

**Installation and
Operation Guide**

1. Index

2.	Presentation	4	12.2	Overall fuel trim	22
3.	Warranty terms	5	12.3	RPM compensation table.....	23
4.	Characteristics	6	12.4	Acceleration fuel enrichment.....	23
5.	Installation	7	12.5	Engine temperature fuel compensation	23
5.1	Electrical wiring connections – main wiring	7	12.6	Air temperature fuel compensation	24
5.2	Main harness schematic	8	12.7	Battery voltage fuel compensation.....	24
5.3	Main switch installation (optional) – important tips.....	9	13.	Ignition tables adjust.....	24
5.4	Built-in MAP sensor	9	13.1	Main ignition table (RPM).....	24
5.5	CAN/USB cable	9	13.2	Overall ignition trim	24
6.	Sensors	9	13.3	MAP/TPS ignition compensation.....	25
6.1	Intake air temperature sensor	9	13.4	Engine temperature compensation	25
6.2	Engine temperature sensor	10	13.5	Air temperature compensation	25
6.3	Fuel and oil pressure sensor – PS10-B sensor	10	14.	Auxiliary functions adjust.....	26
6.4	Throttle position sensor (TPS).....	10	14.1	Internal datalogger	26
6.5	Crankshaft position sensor (CKP)	10	14.2	Engine start	27
6.6	FT250 RPM signal - crankshaft trigger wheel	10	14.3	Revolution limiter	27
6.7	FT300 RPM signal - crankshaft trigger wheel	10	14.4	Deceleration cut-off	27
7.	Fuel injectors	12	14.5	Anti-Lag – turbo spooling	27
7.1	High impedance fuel injectors.....	12	14.6	Two-step rev. limiter	28
7.2	Low impedance fuel injectors	12	14.7	Time based RPM control	28
8.	Ignition.....	12	14.8	Idle speed by timing control	28
8.1	Ignition with distributor.....	12	14.9	Burnout mode	29
8.2	Ignition with crankshaft trigger wheel - FT250.....	12	14.10	Electric fan	29
8.3	Ignition with crankshaft trigger wheel – FT300.....	12	14.11	Idle actuator	29
9.	Auxiliary outputs.....	14	14.12	Shift alert	30
9.1	Electric fan	14	14.13	Fuel pump.....	30
9.2	Idle actuator	14	14.14	Variable camshaft control	30
9.3	Shift alert	14	14.15	Progressive nitrous control.....	30
9.4	Fuel pump.....	14	14.16	Boost control	30
9.5	Variable camshaft control/Powerglide gears	14	15.	Input/Output setup.....	31
9.6	Progressive nitrous control.....	14	15.1	O2 sensor input	32
9.7	Boost control	15	15.2	MAP/MAF voltage clamber (exclusive FT250).....	33
10.	Configuration and settings – step by step.....	16	16.	Interfaces and alerts.....	34
10.1	First step – fuel injection setup	16	16.1	Check control	34
10.2	Second step – ignition setup.....	17	16.2	Backlight settings	34
10.3	Third step – generate FuelTech default setting	19	16.3	Security passwords setup	34
10.4	Fourth step – sensors check-up and (TPS) calibration.....	20	16.4	Initial screen configuration.....	35
11.	Starting the engine for the first time.....	20	16.5	Serial number and software version.....	35
11.1	Ignition calibration.....	20	17.	Files manager – memory positions and functions	35
12.	Fuel injection tables adjust	21	18.	Full wiring diagram.....	36
12.1	Main fuel table (load).....	21			

2. Presentation

FuelTech FT250 and FT300 are fully stand-alone real-time programmable electronic fuel injection systems. They allow the adjustment of all injection and ignition maps according to the engine and its characteristics. The programming can be done directly on the module with the use of its buttons, or through the computer software with communication connection via CAN-USB converter. With the software, the user has access to 2D and 3D maps that facilitate the visualization and the engine tuning. It can be applied to any type of Otto cycle engines, 2T or 4T engines, motorcycle engines and aquatic crafts with automotive engines, stationary engines, among others.

This module features configurable alerts for RPM excess, oil and fuel pressure, air and engine temperature, and others. The alerts can be programmed to cut-off the engine for greater safety. The injection system also has 5 totally independent maps, which allow 5 different configurations for engines and/or cars. Ignition control can be done with the use of a Hall Effect distributor or a crankshaft trigger wheel distributor with no need of additional modules, just the ones regarding ignition and driving of low impedance fuel injectors. In order to facilitate the assembly and tuning of 5 and 6-cylinder engines, this module can directly drive up to 12 high impedance fuel injectors.

Through the computer software, the user can see all parameters configured and read by real-time fuel injection, as well as save all fuel injection configurations on the computer and transfer them to another module with no information loss.

3. Warranty terms

The use of this equipment implies the total accordance with the terms described in this manual and exempts the manufacturer from any responsibility regarding to product misuse.

Read all the information in this manual before starting the product installation.



NOTE

This product must be installed and tuned by specialized auto shops and/or personnel with experience on engine preparation and tuning.

Before starting any electric installation, disconnect the battery.

The inobservance of any of the warnings or precautions described in this manual might cause engine damage and lead to the invalidation of this product warranty. The improper adjustment of the product might cause engine damage.

This product does not have a certification for the use on aircrafts or any flying devices, as it has not been designed for such use purpose.

In some countries where an annual inspection of vehicles is enforced, no modification in the original fuel injection system is permitted. Be informed about local laws and regulations prior to the product installation.

Important warnings for the proper installation of this product:

- Always cut the unused parts of cables off – NEVER roll up the excess as it becomes an interference capturing antenna and it can result on equipment malfunction.
- The black wire of the harness MUST be connected directly to the battery negative, as well as all sensor grounds.
- The black / white wire MUST be connected directly to the battery negative. This avoids many problems with interference.



IMPORTANT

The grounds (black and black / white wires) must NOT be joined before connected to the negative battery terminal.

Limited warranty

This product warranty is limited to one year from the purchase date and covers defects from manufacturing origin only.

Defects and damages caused by the misuse of this product are not covered by the warranty.

This module has a serial number that is linked to the purchase invoice and to the warranty. In case of product exchange, contact FuelTech.

The violation of the seal results in the invalidation of the Product Warranty and the loss of any access to new upgrade releases.

Manual version 2.0

January/2020

4. Characteristics

Specifications and inputs

- Maximum RPM: 16000
- Inner MAP Sensor with absolute pressure of 100psi, (14.5psi to vacuum and 87psi to positive pressure)
- 1, 2, 3, 4, 5, 6, 8 and 10-cylinder engines
- Throttle Position Sensor (TPS) can be calibrated to any linear sensor
- Engine and Intake Air Temperature Sensor
- Oil and Fuel Pressure Sensor
- 4 Configurable Auxiliary Outputs
- Ignition Control with crankshaft trigger wheel (FT300 only) or distributor
- Drives up to 12 fuel injectors in 2 independent sets. More fuel injectors can be controlled when using the Peak and Hold module

Functions

- Internal Datalogger
- Main map options: Aspirated by TPS, Aspirated by TPS/MAP, Aspirated by MAP, Turbo by MAP
- Idle speed control adjustment options: by MAP or TPS
- Real-time programmable on the equipment or with the PC software
- Fuel injection and ignition map based on RPM
- Main fuel table overall trim function
- Acceleration fuel enrichment by MAP or by TPS
- Compensation of ignition timing based on turbo vacuum and pressure or throttle position sensor (TPS)
- Compensation of fuel injection and ignition based on engine and air temperature (11 temperature points)
- Compensation of fuel injection based on battery voltage (with 1.0V interval)
- Rev limiter based on fuel cut-off, ignition cut-off, or ignition and fuel cut-off
- Deceleration fuel cut-off
- Two-step with anti-lag
- Burnout Mode
- Electronic control of the electric fan based on temperature
- Idle air valve control based on engine temperature, minimum RPM and after-launch
- Adjustable engine starting injection based on engine temperature (3 parameters)
- Electric fuel pump control
- Variable Valve Timing Control System (VTEC)
- Progressive nitrous control with mixture enrichment and timing retard
- Boost pressure control based on RPM, with mixture enrichment
- Oil and fuel pressure sensors
- User and tuner protection passwords
- Fuel injector dead time adjustment for injector's real duty cycle calculation

- MAP voltage clamper (FT250 Only)
- Visual and sound shift alert and output for external shift light switching
- Check control with warning and engine cut-off based on exceeded pressure, exceeded RPM, engine temperature, saturated injectors, oil pressure, fuel pressure and fuel differential pressure
- LCD Display backlight adjustment
- 5 memories to save different adjustment from map sets

On-board computer – dashboard screen

- Fuel injectors' current and maximum injection time (in milliseconds, ms) from each set
- Ignition timing (in °BTDC), injection time (in ms), RPM and TPS (in %)
- Ignition timing: minimum and maximum values reached (in °BTDC)
- MAP pressure: current and maximum value reached (in psi)
- Throttle Position Sensor (TPS): current and maximum value reached (in %)
- RPM: current and maximum value reached
- Current Intake Air Temperature: lowest and highest temperatures reached (in F)
- Engine Temperature: current and highest temperatures reached (in F)
- Oil Pressure: current, lowest and highest (in psi)
- Fuel Pressure: current, lowest and highest (in psi)
- Percentage of boost used, ignition timing and boost pressure
- Percentage of nitrous used, ignition timing and enrichment percentage
- Battery Voltage

Dimensions:

- 5.5" x 3.1" x 1.2"

5. Installation

For FuelTech installation, the electric cable must be disconnected from the module and the vehicle's battery. It is very important that the cable length is as short as possible and that unused parts of wires are cut off. Never roll up the excess of any wire in the cable; by doing so, interference problems, which are very usual with any electronic device, are avoided.

Choose an appropriate location to affix the module inside the car, and avoid passing the cable wires close to the ignition wires and cables, ignition coils and other sources of electric noise. Avoid placing the ECU at the engine compartment or where it may be exposed to liquids and heat. DON'T EVER, under any circumstance, install the ECU near the

ignition module in order to avoid the risk of interferences.

The black wire in the cable is the signal ground wire, and must be connected to the battery's negative terminal. The black/white wire is the power ground wire, and must be connected to the vehicle's chassis.

The electric cable must be protected from contact with sharp parts on the vehicle's body that might damage the wires and cause short circuit. Be particularly attentive to wires passing through holes, and use rubber protectors or any other kind of protective material to prevent any damage to the wires. At the engine compartment, pass the wires through places where they will not be subject to excessive heat and will not obstruct any mobile parts in the engine. Always, when possible, use plastic insulation on cables.

5.1 Electrical wiring connections – main wiring

Wire Color	Pin	Connection	Observations
Green	1	Tachometer output	RPM Signal output for tachometers and auxiliary modules.
Yellow – 3	2	Auxiliary output	Must be configured prior to the installation
Yellow – 2	4		
Yellow – 1	6		
Yellow – 4	8		
White/Blue	3	Input – intake air temperature sensor	The other sensor pin must be connected to the negative.
Pink	7	Input – engine coolant temperature sensor	
White	5	Input fuel or oil pressure sensor or lambda	Must be configured in accordance with the sensor used.
Blue	9	Input fuel or oil pressure sensor or Two-Step	Must be configured in accordance with the sensor used. Two-step button (activated by negative signal).
Orange	11	Signal from the TPS sensor	Connect the 3 TPS wires in a way which, when measuring the resistance between the green/red and black wires in the cable, the value does not vary.
Gray – E	10	Ignition output E	With FT250 only ignition output A is used. To control crank trigger, use a FuelTech FirePRO or Fire4S With FT300 all ignition outputs can be connected to coils or ignition modules
Gray – D	12	Ignition output D	
Gray – C	14	Ignition output C	
Gray – B	16	Ignition output B	
Gray – A	18	Ignition output A	
Yellow/Red	13	MAP signal output	Connected to a datalogger, it informs the pressure/vacuum read by the injection inner MAP.
Green/Yellow	15	Cam sync input MAP/MAF voltage clamber	With FT250 – connected to OEM ECU MAP signal. Check chapter 15.1. With FT300 – cam sync sensor input. Check chapter 5.7.3
Shielded Cable	17	RPM signal input	With FT250 – connect to signal from a hall effect distributor or to FirePRO or Fire4S – do not use the shield. With FT300 – connect to crank trigger sensor (magnetic or hall effect) or to hall effect distributor
Black	19	Battery's negative terminal	Must be directly connected to the battery; no add-ons or seams allowed. Cannot be connected to vehicle chassis.
Green/Red	20	5V feed for sensors	Feed for TPS, as well as other sensors.
Red	21	Switched 12V supply	Connect directly to ignition switch.
Black/White	22	Power Ground	Connected directly to the battery negative, seamlessly. Do not join this wire with the black wire before the battery terminal. They can only
Brown	23	Negative terminal from fuel injectors – Bank "B"	See chapter 6 in this manual for more information about these outputs and their connections
Purple	24	Negative terminal from fuel injectors – Bank "A"	

5.2 Main harness schematic

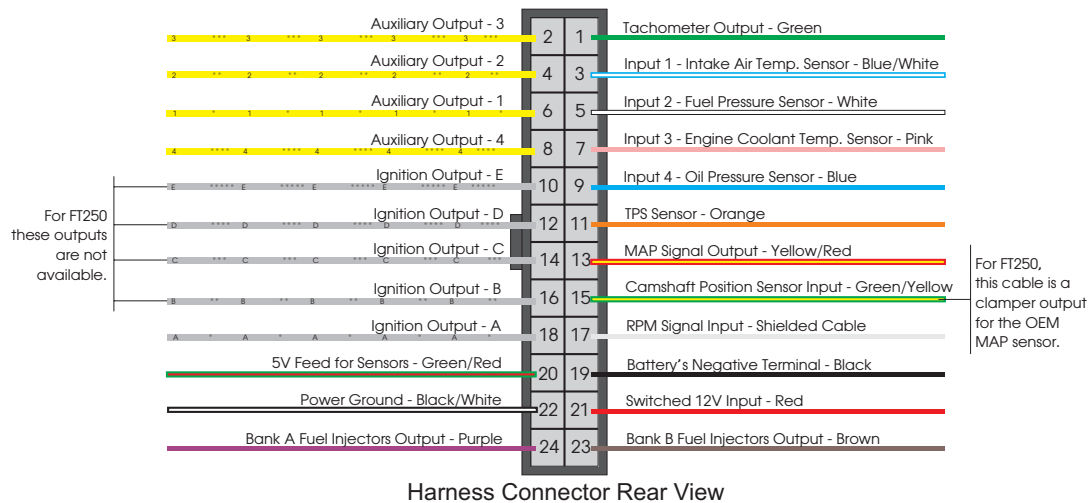

Red wire – switched 12V

Being the 12V input to FuelTech ECU, this wire must be connected to a 12V straight from the ignition switch, no relay needed, just a 5A fuse. It cannot be split with a positive to coils or to fuel injectors.

- 12V for fuel injectors: use a 14 AWG connected to a 40A relay. For up to 4 injectors, a 20A fuse is recommended. For up to 8 injectors, a 30A fuse is recommended. Low impedance injectors (below 10 ohms), when used without a Peak and Hold driver, require a 3,3ohms or 2,7ohms ballast resistor (20W or 25W), connected in series with each fuel injector to avoid damage to the ECU. But be aware that when using low impedance injectors with ballast resistor, each ECU injector output can drive only two injectors.
- 12V for Hall Effect distributor and sensors: use a 24 AWG wire straight from the ignition switch. It can be Split with the ECU 12V. No relay needed. Do not split this wire with a 12V that feeds fuel injectors or coils. Examples: hall effect sensors, pressure sensors, etc.
- 12V for coils and fuel pump: use a wire with at least 14 AWG connected to a 40A relay. Each relay can feed up to 2 fuel pumps or 5 coils. A 30A fuse is recommended.

When using individual coils (COP), it is recommended a 70A or 80A relay.

NEVER split the 12V that feed injectors, coils or their accessories, because, after shutting the engine off, there's a risk of reverse current that may damage a sensor.

Black wire – battery's negative

This wire is responsible for signal ground to the ECU so, it must be connected straight to the battery's negative terminal, with no seams. No hypothesis this wire can be connected to the vehicle chassis or split with the ECU black/white wire (power ground). This will cause electromagnetic interference and other problems hard to diagnose and to solve.

The black wire must have permanent contact with the battery's negative terminal, never being connected to switches, car alarms or others. To turn a FuelTech ECU off, the red wire should be switched on and off.

- Negative for sensors (TPS, air temp., pressure, rpm, distributor, etc.): It is vital to use sensors ground straight to the battery's negative terminal. Connecting them to chassis may cause electromagnetic interference, wrong readings or even damage to the sensors.
- To attach the negative wires to the battery terminal use ring terminals and avoid soldering them. A well crimped terminal has better resistance than a soldered one. Besides that, solder makes the seam stiffer, and less resistant to vibration, typically found on combustion engines.
- Use a crimping tool and insulate the wire with insulating tape or heat shrink tubing.

Black/White wire – power ground

This is the FuelTech ECU power ground wire. It must be connected to the battery negative. The power ground (black / white wire) cannot be connected with the Negative signal (black wire) before the battery terminal. This will cause electromagnetic interference and other problems hard to diagnose and to solve.

The black/white wire must have permanent contact with the battery, never being connected to switches, car alarms or others. To turn a FuelTech ECU off, the red wire should be switched on and off.

- Power ground to ignition modules (SparkPRO, etc.), Peak and Hold drivers, relays and other accessories, must be connected to the same point, with the battery's shield on the chassis.
- An important point is that the battery's shield must be in good shape. It is strongly recommended to replace it in the event that it is heavily worn.

- A good test to check the connection resistance of the power grounds is, using a tester, to measure the resistance between the battery's negative terminal and the chassis ground. Connect the red probe on the chassis point that the shield is connected and the black probe on the battery's negative. With the tester on the 200ohms range, the resistance measured must be below 1 ohm. Remember to touch both probes to check its resistance. This reading must be subtracted from the first reading to found the correct value.

5.3 Main switch installation (optional) – important tips

Main switches are being used for a long time in competition vehicles for safety purposes in case of an accident. In just a few seconds, the entire power on the vehicle can be shut down, avoiding short circuits that can worsen the situation. And, just like any other electric accessory, there's a correct way to install it. The main switch must ALWAYS control the battery's positive (12V).

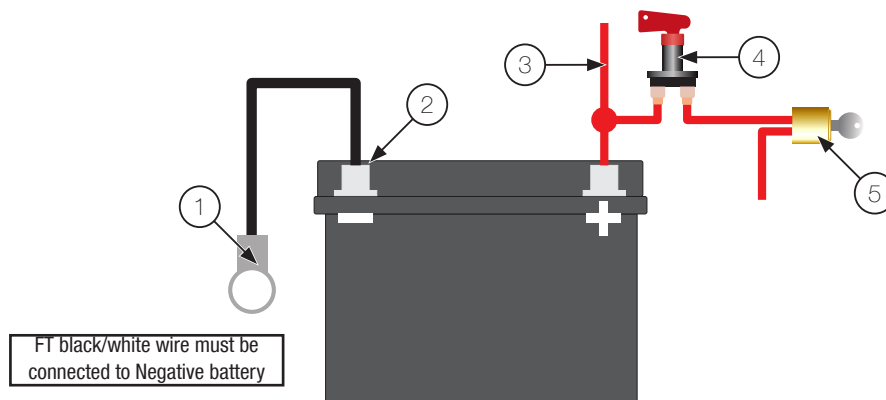

- | | |
|-------------------------------------------------------------------------------------------------------------------------------|---------------------------------|
| 1 - Shield connecting battery negative to chassis and engine | 3 - Positive wire to alternator |
| 2 - Black and black / white wires of the FT on the battery negative (cannot be joined before reaching the battery's terminal) | 4 - Main switch |
| | 5 - Ignition Switch |
| | 6 - Switched 12V |

5.4 Built-in MAP sensor

This FuelTech ECU is equipped with a built-in MAP sensor on its back. It is recommended to use a polyurethane hose, found on pneumatic machines. The hose must have 4mm of internal diameter (and usually 6mm of external diameter).

Silicone hoses are not recommended because they are easily kinked and can block the vacuum signal to FT ECU.

The hose must go from the FuelTech MAP sensor straight to the intake manifold after the throttle body, this means, any point between the throttle body and the engine head. When using individual

throttle bodies, it is necessary to connect each intake runner with "Y" connections, and then connect this to the ECU MAP sensor. Otherwise, the reading will be incorrect and unstable.

5.5 CAN/USB cable

On the rear side of the ECU, there is a 4-way connector labeled CAN. This connection must be used with a CAN/USB converter for communication with a PC and access to upgrades via INTERNET.

6. Sensors

6.1 Intake air temperature sensor

The use of this sensor is optional, but when installed, it is automatically detected by the injection system. It allows to monitor the intake air temperature in real-time through the dashboard screen, verify the highest temperatures reached and compensate the mixture automatically based on air temperature.

With this sensor, it is possible to automatically compensate for climate variations, changes in air temperature between daytime and night time, and changes between seasons throughout the year. Any temperature difference requires a fine-tuned compensation in the mixture in order to keep the desired performance and efficiency.

The sensor that must be used is the Delphi / NTK (3.3kΩ at 20°C) standard, similar to the ones used by Fiat, which has a metal structure and can be threaded into a boss welded to the intake manifold.

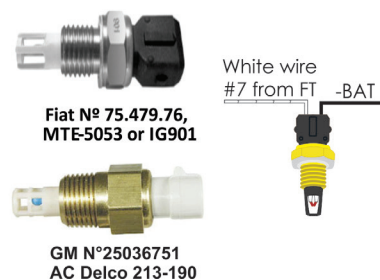

6.2 Engine temperature sensor

The use of this sensor is key for the proper operation of the engine in all temperature ranges, especially when running cold, shortly after starting up for launch.

In cars with water cooling system, this sensor must be placed in the cylinder head, preferably in the original coolant temperature sensor port. In cars with air cooling system, this sensor can be placed in the engine oil, as the fluid represents the temperature in which the engine works.

The Delphi / NTK (3.3k Ω at 68 F) standard model must be used

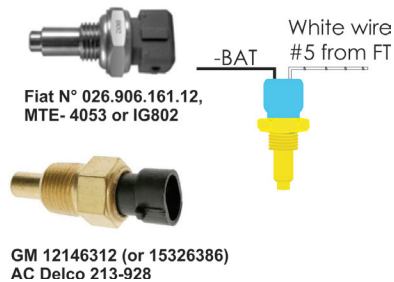

6.3 Fuel and oil pressure sensor – PS10-B sensor

The use of this sensor is optional, but when installed, it is automatically detected by the ECU. It allows to monitor fuel or oil pressure in real-time through the dashboard screen. With the Check Control function, it is possible to program pressure warnings. When installing this sensor, the ECU must be configured at the "Input/Output Setup" menu.

This pressure sensor performs general pressure readings (fuel, oil, etc.). It can be purchased online (www.fueltech.net) or from FuelTech dealers (check the website to locate the dealer nearest to you).

FuelTech PS-10B Sensor Specifications:

- Output Signal: 1 to 5V
- Electric Connections:
 - o Pin 1: Battery's Negative
 - o Pin 2: Output Signal 1 to 5V
 - o Pin 3: Switched 12V
- Connection: 1/8" NPT
- Pressure Range: 0 to 145psi
- Feed Voltage: 12V
- Body structure in stainless steel and IP67
- Accuracy (including nonlinearity, hysteresis, and repeatability): +/- 0.5% at maximum readings range.
- Electric Connector: 3-way AMP Superseal (FuelTech Code 1014)



6.4 Throttle position sensor (TPS)

The Throttle Position Sensor (TPS) is a potentiometer placed on the throttle body in order to inform its angular position. The TPS is the main sensor in the injection system when used in an aspirated engine without steady vacuum. When the engine is an aspirated by MAP, or Turbo by MAP, the TPS can be used to regulate the idle, the acceleration enrichment and the deceleration fuel cut-off.

In special cases, the engine can run without this sensor, but all the functions above mentioned will be performed by the MAP (with prejudice to fine-tune adjustment details).

All throttle bodies come with a TPS, and it is recommended that the original TPS is used, as its fixation and flow are in perfect fit to the part it came with. In any event, FuelTech products are compatible with any TPS sensor, as they have calibration functions.

6.5 Crankshaft position sensor (CKP)

In order to control fuel injection and ignition, the module can be connected to a variety of sensor types: distributors with Hall sensor or crankshaft trigger wheels with inductive or Hall Effect sensors. With any of these options, the injection will read the exact position of the engine and of the ignition control system as a whole.

Distributor

To read the RPM signal through a distributor, it should use a Hall Effect sensor (3-wires) and have the same number of windows as the number of cylinders.

On VW AP engines, it is possible to use the distributor from the Gol Mi (with a bigger window) or the distributors with the same window as the older model of the Gol GTi, the older model of the Golf, and other cars with LE-Jetronic fuel injection system.

On GM engines Family I (Corsa) and Family II (Vectra 8V and Calibra 16V), it is possible to use the distributor from vehicles that had electronic fuel injection Le-Jetronic system (Monza, Kadett GSi, Vectra up to 1996) or from the GM Corsa with 3 wires.

Ligação Elétrica do Distribuidor Hall

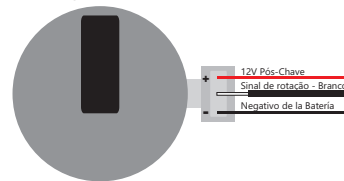

6.6 FT250 RPM signal - crankshaft trigger wheel

FT250 can control ignition through a crank trigger, the use of a FirePRO or Fire4S is needed. Check their instructions manual for more information.

6.7 FT300 RPM signal - crankshaft trigger wheel

Crankshaft Trigger Wheel – Fabrication and Installation

The crankshaft trigger wheel is responsible for informing the exact position of the crankshaft to the electronic ignition management system, in such a way that this system is able to determine the ignition timing in the engine. The trigger wheel is affixed to the crankshaft, outside or inside the engine block, with a specific alignment. Usually, the Crankshaft Trigger Wheels placed on the outside of the block are put in front of the engine, by the front crankshaft pulley, or in the rear of the engine, by the flywheel. There are many types of Trigger Wheels, but the compatible ones are mentioned below:

- **60-2:** this is, in general, the most used type of trigger wheel. It is a wheel with 58 teeth and an open space (fault point) equivalent to two missing teeth, therefore called "60-2". This trigger wheel is found in most Chevrolet (Corsa, Vectra, Omega, etc.), VW (Golf, AP TotalFlex, etc.), Fiat (Marea, Uno, Palio, etc.), Audi (A3, A4, etc.) and Renault (Clio, Scénic, etc.) models, among other car makers. Ford Flex models with Marelli injection use this type of trigger wheel also. Some VW Gol models are equipped with magnetic pickup studs. There are 58 studs, with 2 missing teeth (60-2). Its alignment is 15 teeth from TDC.
- **36-2:** this is the standard in Toyota engines, being 34 teeth and an open space equivalent to two missing teeth.
- **36-1:** this type has 35 teeth and an open space equivalent to one missing tooth. It can be found in all Ford vehicle lines, with 4 or 6 cylinders (except the Flex models with Marelli injection, which use the 60-2 trigger wheel).
- **12-Tooth:** this type is used by AEM's Engine Position Module (EPM) distributor. In this case, the cam sensor from the EPM must be used. This distributor has 24 teeth, but as it rotates half-way for each full engine rotation, there will only be 12 teeth per rotation. Setup the Ignition with 12 tooth and the 1st tooth alignment
- **2, 3, 4, 8-Tooth:** options available according to the number of engine cylinders. When having these trigger wheels, the use of a camshaft position sensor is mandatory, in order to maintain the synchronization of the parts. Also, the teeth must be equidistant. They can be found in models such as Subaru, Mitsubishi Lancer and 3000GT, GM S10 Vortec V6, etc.
- **30-1, 24-1 and 12-1 Tooth:** These are less common types, but they are perfectly compatible. These trigger wheels can operate without a camshaft position sensor, as they have a reference point (fault) that indicates the TDC on cylinder 1.

In order to correctly inform the engine position to the ECU, it is necessary that the injection has the right information about the alignment of the trigger wheel in relation to the TDC on cylinder 1. The image below shows a 60-2 trigger wheel with the sensor aligned on the 15th tooth after the fault (open space). In this image, for example, the engine is on the TDC on cylinder 1. Notice that the rotation is clockwise, and therefore, the TDC on cylinder 1 is set 15 teeth after the sensor passes the fault point. That is exactly the number of teeth that must be informed to the injection upon its configuration.

Crankshaft trigger sensor

When controlling the ignition with a trigger wheel, it is necessary to have a sensor that reads the signal from its teeth and informs the engine position to the injection. There are two types of crankshaft trigger sensors:

- **Magnetic sensor:** this is the type that is most commonly used in cars nowadays, especially with 60-2 and 36-1 trigger wheels. One of its main characteristics is that it does not receive 12V

or 5V feed, it only generates an electromagnetic signal based on induction. It might have 2 or 3 wires (the third wire is an electromagnetic shield).

- **Hall Effect sensor:** it is usually found on 2, 3 and 4-tooth trigger wheels and some 36-1 and 60-2 types. It receives a 5V or 12V feed and emits a square wave signal. It invariably has 3 pins: feed, negative and signal.

RPM sensor connections

An instructions manual with connections of coils and sensors is available on our website in the manuals section.



NOTE

Always download the latest version of this instructions manual cause it is subject to changes without notice.

Camshaft position sensor

When using a crankshaft trigger wheel and individual ignition coils, it is possible to control ignition in a sequential manner. In this case, a camshaft position sensor is needed, as it informs the exact moment when cylinder 1 is on combustion TDC. Installation and alignment of a camshaft position sensor are very simple procedures, and the only requirement is that the sensor emits a pulse to the injection a little before reaching the TDC on cylinder 1.

To check the connection of several cam sensors, refer to the coil and sensor connection manual on our website in the manuals section.

7. Fuel injectors

Every injection output can drive up to 6 high impedance fuel injectors (resistance greater than 10 ohms) or up to 2 low impedance fuel injectors (resistance lower than 10 ohms) with power resistors. There is no need for auxiliary modules.

7.1 High impedance fuel injectors

The diagram below shows the direct connection of six high impedance fuel injectors to one of the injection's output. As it is, up to 12 fuel injectors can be controlled with no need for auxiliary modules (6 on each output). It is also possible to connect a lesser number of fuel injectors per output.

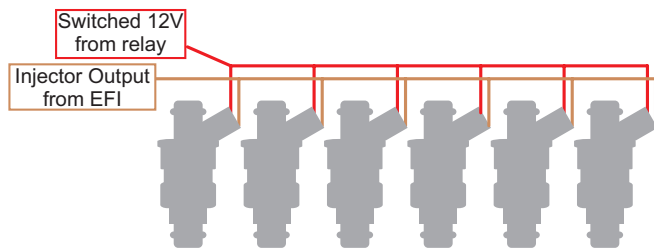

7.2 Low impedance fuel injectors

The next diagram shows the connection of two low impedance fuel injectors to one of the injection's output, with the use of power resistors.

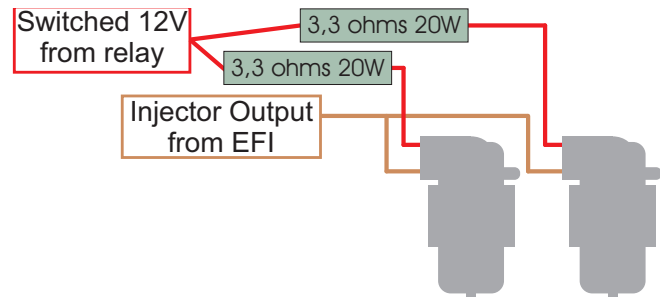

Low impedance fuel injectors may only be installed along with resistors when used as supplementary injectors on turbocharged engines. If the use of low impedance fuel injectors is needed to control the low charge and the engine's aspirated phase, the use of a FuelTech Peak and Hold module is highly recommended, as it is able to control the injectors current for a more precise injector opening event.

FuelTech ECUs are compatible to any Peak and Hold module in the market.

8. Ignition

FT250 has one ignition output that is used to trigger one ignition coil. Ignition can be controlled through a hall effect distributor or a crank trigger (addition module – FirePRO or Fire4S – is needed).

FT300 has a total of 5 ignition outputs to trigger coils in wasted spark or coil-on-plug.

8.1 Ignition with distributor

When using the injection along with a distributor, only the ignition output "A" shall be used. The wire must drive a coil with an integrated ignition module or an ignition power module.

Coil with integrated ignition module

These coils have at least 3 input wires and only one output for ignition cable, such as the one used in the VW Gol Mi, with 3 wires. It is recommended to set the charge time (Dwell) around 3,60ms in order to protect the coils from overcharging. When using this type of ignition coils, the "Ignition Output" parameter must be configured as "Fall (inductive)". If the output is not correctly selected, the ignition coil will be damaged in seconds.

FuelTech SparkPRO-1 with coil without ignition module

FuelTech SparkPRO-1 module is a high-energy inductive ignition with an excellent benefit-cost ratio, and it can be used with any regular 2-wire ignition coil (without internal ignition). It is recommended to use ignition coils with the lowest resistance possible as the primary, like the 2-wire ignition coil from VW AP Mi (Bosch Code: F 000 ZS0

105), in order to have a better use of SparkPRO-1's performance. The primary coil's minimum resistance must be 0.7 ohms; a lower resistance will damage the SparkPRO.

Notice also that this module must be placed the closest possible to the ignition coil.



Warning about the SparkPRO-1:

An excessive charge time (Dwell) can damage the SparkPRO and the coil. It is recommended to use a 3,60ms Dwell and watch its temperature during normal engine operation. If the temperature rises greatly, immediately lower the Dwell. Be very careful!

Important note: The Ignition output must be configured as "Fall (inductive)". If the output is not correctly selected, the ignition coil will be damaged in seconds!

8.2 Ignition with crankshaft trigger wheel - FT250

FT250 can control ignition through a crank trigger, the use of a FirePRO or Fire4S is needed. Check their instructions manual for more information.

8.3 Ignition with crankshaft trigger wheel – FT300

In a distributor less ignition, a static ignition system, with double or individual coils per cylinder, is needed. In this system, the coils are switched by different outputs, depending on the cylinder to which

they are connected. The ignition outputs always pulse in a sequential manner from "A" to "E", therefore these outputs must be connected to

the coils in accordance to the engine's ignition sequence. Find below examples of some engines' ignition sequence and the connection to some coils.

Individual ignition coils – electrical wiring table

4-Cylinder Engines: great **majority** of engines (VW AP, VW Golf, Chevrolet, Ford, Fiat, Honda, etc.)

Firing Order: 1-3-4-2	1	3	4	2
Coils' Ignition Sequence:	A	B	C	D

4-Cylinder Engines: **Subaru**

Firing Order: 1-3-2-4	1	3	2	4
Coils' Ignition Sequence:	A	B	C	D

4-Cylinder Engines: **VW Air-cooled**

Firing Order: 1-4-3-2	1	4	3	2
Coils' Ignition Sequence:	A	B	C	D

5-Cylinder Engines: **5-Cylinder Audi and Fiat Marea 20V**

Firing Order: 1-2-4-5-3	1	2	4	5	3
Coil's Ignition Sequence:	A	B	C	D	E

Double ignition coils – electrical wiring table

When there are double ignition coils, it is necessary that each ignition output switches more than one coil, as shown in the diagrams below:

4-Cylinder Engines: when using double coils, use the ignition sequence shown in the previous chapter, exchanging the output C to A, and the output D to B

6-Cylinder Engines: GM inline engine (Opala and Omega), VW VR6, Ford inline engine and BMW inline engine

Firing Order: 1-5-3-6-2-4	1	5	3	6	2	4
Coils' Ignition Sequence:	A	B	C	A	B	C

The cylinders 1 and 6 are connected to coil A, the cylinders 2 and 5 are connected to coil B, and the cylinders 3 and 4 are connected to coil C.

6-Cylinder Engines: GM V6 (S10 / Blazer 4.3)

Firing Order: 1-6-5-4-3-2	1	6	5	4	3	2
Coils' Ignition Sequence:	A	B	C	A	B	C

The cylinders 1 and 4 are connected to coil A, the cylinders 3 and 6 are connected to coil B, and the cylinders 2 and 5 are connected to coil C.

6-Cylinder Engines: Ford Ranger V6

Firing Order: 1-4-2-5-3-6	1	4	2	5	3	6
Coils' Ignition Sequence:	A	B	C	A	B	C

The cylinders 1 and 5 are connected to coil A, the cylinders 3 and 4 are connected to coil B, and the cylinders 2 and 6 are connected to coil C.

8-Cylinder Engines: Chevrolet V8 (most of the engines)

Firing Order: 1-8-4-3-6-5-7-2	1	8	4	3	6	5	7	2
Coils' Ignition Sequence:	A	B	C	D	A	B	C	D

The cylinders 1 and 6 are connected to coil A, the cylinders 5 and 8 are connected to coil B, the cylinders 4 and 7 are connected to coil C, and the cylinders 2 and 3 are switched on coil D

8-Cylinder Engines: Ford 302, 355, 390, 429, 460

Firing Order: 1-5-4-2-6-3-7-8	1	5	4	2	6	3	7	8
Coils' Ignition Sequence:	A	B	C	D	A	B	C	D

8-Cylinder Engines: Ford 351, 400 and Porsche 928

Firing Order: 1-3-7-2-6-5-4-8	1	3	7	2	6	5	4	8
Coils' Ignition Sequence:	A	B	C	D	A	B	C	D

8-Cylinder Engines: Mercedes-Benz

Firing Order: 1-5-4-8-6-3-7-2	1	5	4	8	6	3	7	2
Coils' Ignition Sequence:	A	B	C	D	A	B	C	D

9. Auxiliary outputs

The current capacity of these outputs is 0.5A, and therefore they can drive solenoids or relays with 25Ω of minimum resistance. The installation of a fuse equivalent to the charge is recommended.

The auxiliary outputs have an over-current protection system, with automatic cut-off of current and the activation of loads (lamps, relays, etc.) always originated from the negative terminal. Thus, the positive terminal must be connected to a switched 12V. The yellow wires numbered 1 to 4 are the configurable auxiliary outputs.

Each output must be configured in accordance to its function. For more information about the outputs programming, see chapter 14 in this manual. Notice that the configuration is not lost when the output is deactivated.

9.1 Electric fan

This output is responsible for switching an electric fan according to the module's settings. The relay used must be adequate to the electric fan's current (50A, for example).

The relay is switched by negative (sourced by the output), and the positive a switched 12V.

9.2 Idle actuator

A valve is used to increase the air flow through intake, and therefore, increase the engine RPM. FuelTech recommends the use of an idle speed actuator that works through PWM, or a valve that is usually closed, as booster and canister solenoid valves, for example.

The relay must be adequate to the valve's current, driven by the negative sourced by this same output. The positive for the relay must be connected to a switched 12V.

Through this setting, an alternative air passage is created, which increases the air flow to the intake manifold, even when the throttle is closed. A new airway from pressurization or air intake is opened from the engine to the intake manifold, which must pass through a solenoid valve. As the valve does not let the air through when not activated, the system will not interfere in unwanted situations. When necessary, the valve will open the extra air passage to the engine in order to increase or maintain the idle speed RPM, according to the case.

This idle speed control helps in situations when the engine requires more air to maintain the idle speed RPM to a wanted level, such as:

Engine start: the control is activated for 3 seconds until RPM is stabilized.

Cold engine operation: control in this situation is very important, as the cold engine tends to be turned off because of its need of more air to keep operating than when hot. The opening of the valve can be regulated to a lower rpm level for when the engine is hot.

Engine operation with a higher load: for example, when the electric fan or the air-conditioning is turned on, an extra load is put on the engine, and, consequently, more air intake is needed.

This control does not pulsate; therefore, it is necessary to keep a small opening on the air control valve through the screw responsible for its actuation. Such opening must be regulated as to maintain a stable idle speed when the engine is hot.

If the engine RPM increases sharply when the valve is switched, a restrictive device must be put on the air passage to the valve, such as a jet hole, similar to the ones used in mechanical booster systems.

9.3 Shift alert

This function activates an external shift light and works by sending negative when turned on. Any of the options below can be used:

- 12V light bulb up to 5W: switched 12V directly connected to the light bulb and the negative connected to the auxiliary output.
- Light bulb over 5W: use a relay to switch the light bulb.
- LED working as a Shift Light, which must be connected with a serial resistance (if used in 12V, resistance from 390Ω to $1k\Omega$) to the switched 12V.
- Any "Pen" Shift Light – working in the same way as a light bulb.

9.4 Fuel pump

The fuel pump switching must be done through a relay dimensioned in accordance to the pump's working current. The output sends out negative to activate the relay, which stays activated for 6 seconds and turns itself off if the injection does not receive any RPM signal. When the injection captures the RPM signal, it activates the fuel pump once again.

9.5 Variable camshaft control/Powerglide gears

The camshaft control systems that use solenoid valve type NA/NF such as Honda's VTEC, can be controlled through this output. The user only needs to inform the solenoid's turn on RPM.

It is important to notice that the impedance of the variable control system's solenoid must respect the auxiliary output limits, which requires a minimum impedance of 25Ω , or the use of a relay. For valve timing control systems switched by PWM (such as Toyota's VTI), it is possible to manage it through the Boost Control function, as long as its characteristics (power, current, etc.) are within the auxiliary output limits.

This resource can also be used to switch the control solenoid from the 2-speed automatic gear control, Powerglide type. Inform the RPM to turn on the solenoid responsible for engaging the second gear.

9.6 Progressive nitrous control

This function drives the solenoids used for the injection of nitrous oxide in the engine. As these solenoids have high power (90W) and low impedance ($\sim 1.6\Omega$), they cannot be connected directly to the auxiliary output; the use of a Solid state relay is necessary to drive the solenoid(s), which must be connected as shown in the image below:

The cable pointed by the arrow in the image beside is an auxiliary output that must be configured as "Progressive Nitrous Control" to work properly. All Peak and Hold inputs may be connected to the configurable auxiliary output chosen to control more nitrous solenoids. The Peak and Hold channels not used for nitrous control can be used to drive fuel injectors, if needed.

There are two ways of using the nitrous control: with or without fuel injection through the fogger. The first option is also the most used one, in which the fogger injects both nitrous oxide and fuel.

In the second option, the fogger only injects nitrous, so called “dry nitrous”. Fuel enrichment is managed by the injection, increasing injection times based on what has been programmed. The dry nitrous system has reached better results in tests, giving the engine a more linear power than the first option. It is important to clarify that in order to use the dry nitrous system, the fuel injectors must be dimensioned for the power reached with the nitrous, and otherwise will not be able to feed the engine.

It is recommended that one of the injection maps is used specifically for nitrous when using a dry nitrous system, because injection timing adjustments are:

- Different from the ones usually made for engines that don't use nitrous
- Set on the compensation map based on RPM.

There is a difference in the operation of solenoids that control nitrous injection and the ones that control fuel injection: nitrous solenoids start pulsing after 5%; fuel solenoids only pulse after 20%. Variations may occur among solenoids from different brands/manufacturers.

When applying the conventional nitrous control, one must start with a minimum injection time of 20%, but when using dry nitrous, it is possible to start with 5%, as the injectors – and not the solenoid – will control fuel injection.

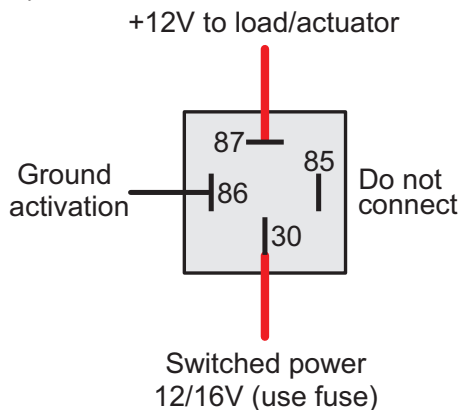

9.7 Boost control

This auxiliary output configuration allows the driving of a boost pressure control solenoid. FuelTech recommends using a 3-way N75 solenoid, found in the original 4 and 5-cylinder VW/Audi Turbo models, which can be directly switched through the auxiliary output.

Such solenoid valve controls the pressure on the top and bottom parts of the wastegate valve, changing the pressure with which the latter opens. FuelTech does not recommend the use of this solenoid when reaching pressure levels above 36psi, as leakage may occur.

Wastegate at the exhaust manifold

This type of valve is used on most cars with adapted turbo, in competitions, etc.

Example 1: the first way to install a boost valve is connecting it to the bottom of wastegate valve, similar to the OEM installing in the VW 1.8T. Select the output signal as activated at 0V and frequency at 20Hz.

This way the boost valve will decrease the pressure under the wastegate to increase boost pressure.

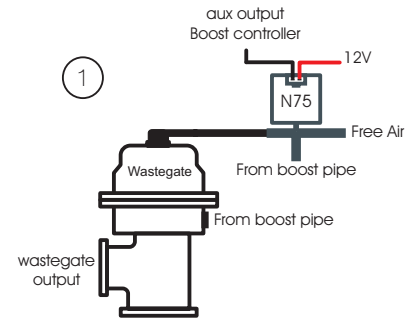

Example 2: the second way is to connect the boost solenoid to the top of wastegate.

Select the output signal as activated at 12V and frequency at 20Hz. This way, the boost valve will increase the pressure at the top of wastegate to increase boost

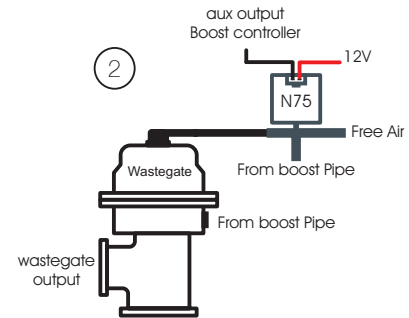

Wastegate integrated to the turbine

This valve has a different operation system, as it relieves the boost pressure when pressure is put on its top part, which is the opposite of what happens to the wastegate installed at the exhaust manifold. Select the output signal as activated at 0V and frequency at 20Hz. With this kind of wastegate, the boost valve relieves the pressure in top of wastegate to increase boost pressure

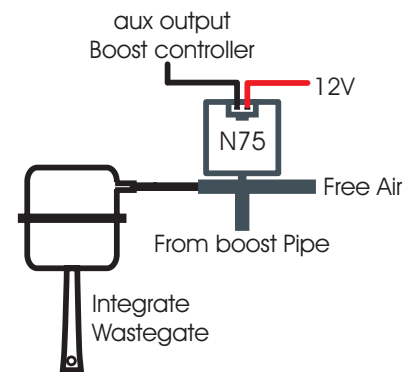

IMPORTANT
Be very CAUTIOUS when using this resource. When values close to 100% boost have been programmed, the turbine may generate full pressure, which may cause engine damage if it has not been properly prepared to support the pressure levels reached.

All injection maps used for data processing are formed by the interpolation of values supplied in the tables; therefore, if a certain RPM is not an exact value found in the RPM tables, an interpolation will produce the exact value between the closest ones.

10. Configuration and settings – step by step

10.1 First step – fuel injection setup

In this menu, data regarding the engine and injection control modes must be informed.

Maximum RPM: it is the maximum RPM value to which the fuel injection maps will be limited, i.e., the RPM Compensation Table based on RPM will be created up to the limit value informed in this menu. This parameter is also used for the calculation of the fuel injectors' opening percentage, shown in the Main Fuel Table.

Type of engine and choice of regulation parameter for Idle speed: in this option, the user must select the type of engine (Aspirated or Turbo) and the parameter that will regulate the Idle Speed operation:

- **Aspirated by TPS:** this option is usual for aspirated engines without steady vacuum, whether because it has a competition camshaft, body of throttle valves with small restriction, or simply because of user's choice. The Main Fuel Table will be based on TPS, in which the injection is adjusted at every 10% of opening of the throttle (TPS), from idle speed (TPS 0%) up to full acceleration (WOT – "Wide Open Throttle", TPS 100%).
- **Aspirated by TPS/MAP:** in this option, the Main Fuel Table will be based on TPS, but there is a compensation (in percentage) of injection by MAP, based on the intake manifold vacuum or on the atmospheric pressure only.
- **Aspirated by MAP:** this configuration mode is indicated for aspirated engines with steady vacuum, because the readings of the intake manifold vacuum represents the engine charge better than the opening of the throttle, especially in situations when the RPM varies, as the fix opening of the throttle can represent different levels of vacuum in the engine due to differences of flux at the throttle. Cars with competition camshaft in which the Main Fuel Table is done based on MAP, may have unstable vacuum during idle speed; in this case, FuelTech recommends that the "idle speed by TPS" option is chosen, so, when TPS readings are 0%, the fuel injection will start considering the idle speed value from the Main Fuel Table, disregarding the MAP readings.
- **Turbo by MAP:** in this configuration, the Main Fuel Table is a Fuel Injection x Pressure Map, beginning at -13psi up to the maximum pressure configured (up to 87psi of boost pressure, which means 101psi of absolute pressure). In turbo cars with competition camshaft, one can choose the "idle speed by TPS", as in the previous option.

Maximum boost pressure: When the car has a turbo or blown engine, this option can be configured so the Main Fuel Table is limited above pressures that will not be used. For example, in a car that will use the maximum boost pressure of 29psi, a value of 36psi can be chosen as the maximum pressure (a margin is given for regulation purposes), therefore, the Main Fuel Table will range between -13psi

and 36psi, and for anything above this, the last value in the map will be considered. This parameter does not limit the pressure generated by the turbine, only the maximum value from the Main Fuel Table.

Acceleration enrichment: the acceleration enrichment is the increase in the amount of fuel injected when there is a quick variation of air flux in the engine. This alteration can be compensated by the injection through variation in the throttle (TPS) or in readings of vacuum/pressure in the manifold. As the throttle variation is what generates pressure alterations, the Quick Fuel Injection based on TPS tends to be more effective.

Fuel injector sets:

- **One bank:** the driving of the two injection outputs will happen at the same time, i.e., all injectors connected to the fuel injection system will pulsate together, at once. Then, one set of injectors can be used to feed the whole engine, from aspirated phase up to turbo maximum pressure.
- **Two banks:** the control of the two injection outputs is separate, i.e., each output will have a different behavior, according to what has been programmed in the system. In aspirated engines, the second set can be used to add to or to substitute the first set of injectors (one set next to the cylinder head and the other above the throttle valves, for example). In turbo engines, one set of injectors is used to feed the engine's aspirated phase, and the other set is used to feed the positive pressure phase.

Number of cylinders: the user must inform the number of cylinders in the engine.

Injection mode: this parameter determines how the driving of injectors occurs.

- **Normal:** the injection pulses happen along with the ones from ignition; therefore, there is an injection pulse to each ignition pulse. This mode is used when the injectors are installed near the Throttle Body Injection (TBI).
- **Alternated (recommended):** in this mode, the module will release an injection pulse to every two ignition pulses. This mode must be selected when the injectors are installed near the intake valve (what is usually the standard for cars that were originally manufactured with electronic injection).
- **Wasted spark:** this option is used when RPM signal is captured directly from the negative terminal of a coil working on Wasted Spark System in 4-cylinder cars, called Double Ignition Coil. The signal must be captured in this way especially in cases when the ignition system does not feature a normal RPM output. It is only used when the ignition has been disabled. The RPM is doubled as only half of it is captured.
- **Synchronized:** using this configuration, the fuel injection is synchronized with the engine RPM; therefore, there is one injection pulse for each engine RPM, except when there is an odd number of cylinders. This mode is very much used when

the fuel injectors have a high flow rate. Only available on engines with 6 cylinders or more.

Injectors dead time: all fuel injectors, for they are electromechanical valves, have an opening inertia, which means that there is a “dead

time”, a moment in which the injector has already received an opening signal, but still has not started to inject fuel. This parameter considers, as a standard value, 1.00ms for high impedance fuel injectors, which is taken into account for the calculation of the injection percentage, especially for compensations or quick adjustments.

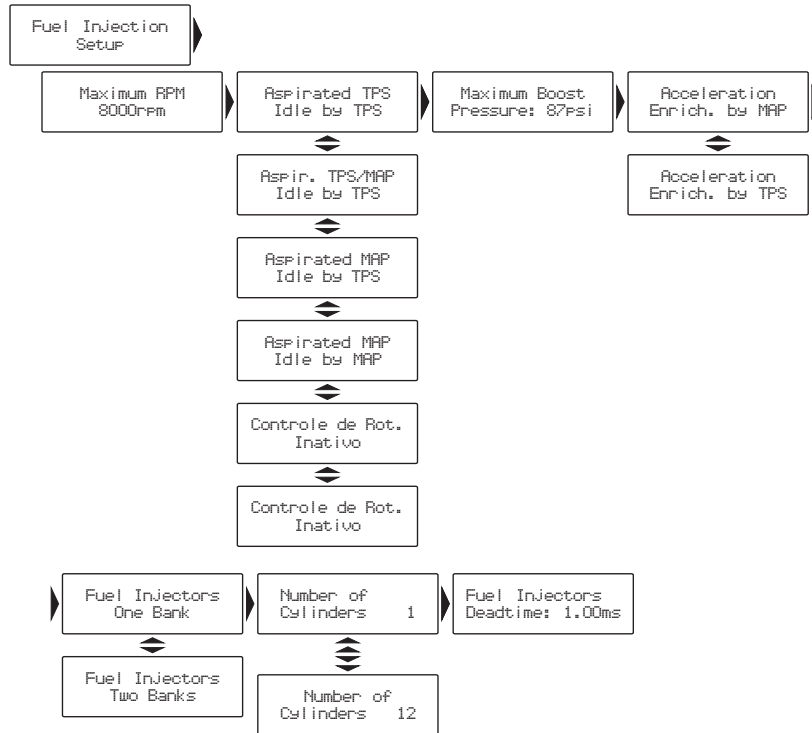

10.2 Second step – ignition setup

The “Ignition Setup” menu must be set to inform how the ignition will be controlled. The “disabled” option inactivates the ignition control, which means that only the injection control will be activated. The “Main Ignition Table” menu stays inactive.

Ignition with distributor

This configuration indicates that the spark distribution will be done by a distributor, and that the engine will only have one ignition coil, despite the number of cylinders. In this case, only the ignition output “A” will send pulses to the coil, the others will be disabled.

RPM sensor angle size: it is the distributor’s window angle. The standard used is 72° for VW MI distributors with a larger window and 60° for distributors from GM 4-cylinders and older models of the VW Gol GTI. In the event of a different distributor, this parameter can be altered. For example, in GM V6 Vortec engines (S10 and Blazer), the standard window is 63°. To find out the distributor angle, see chapter 5.5.1 in this manual for instructions.

Ignition output: Select the ignition type to be used:

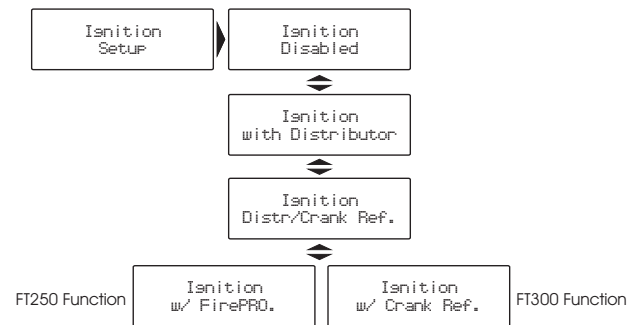

- Fall (inductive): for modern inductive ignition modules, such as the 3-wire Bosch coil, SparkPRO-1, coils with integrated ignition module and Bosch 7-pin ignition module.
- Rise (CDI): it is used for capacitive discharge ignitions type MSD 6A, 6AL, 7AL2, Crane, Mallory and similar others.

Ignition dwell: it is the coil’s charge time, measured in milliseconds. An adequate charge time for most regular coils and ignitions is between 3.00ms and 3.60ms.

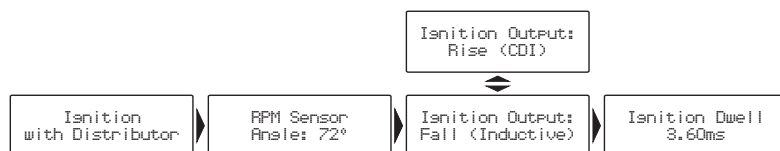

Ignition with crankshaft trigger wheel - FT250

FT250 can control ignition through a crank trigger, the use of a FirePRO or Fire4S is needed. Check their instructions manual for more information.

Ignition with crankshaft trigger wheel – FT300

The selection of the Ignition with Crankshaft Trigger Wheel option (Crank Reference) means that the ignition will be controlled without a distributor. In this case, double or individual ignition coils must be used.

Crank trigger wheel: in this option, the standard type of the trigger wheel used in the engine must be informed (60-2, 36-2, 36-1, 30-1, 24-1, 24, 12-1, 12, 8, 4, 3 or 2 tooth).

Crankshaft reference sensor: inform if the crankshaft reference sensor type is inductive or Hall.

Crank index position: configure the alignment of the trigger wheel used in the engine, informing in which tooth the sensor is positioned when the engine is on TDC (cylinder 1 on TDC). The teeth are counted from the fault reference point (open space with no teeth), counter wise to the engine rotation.

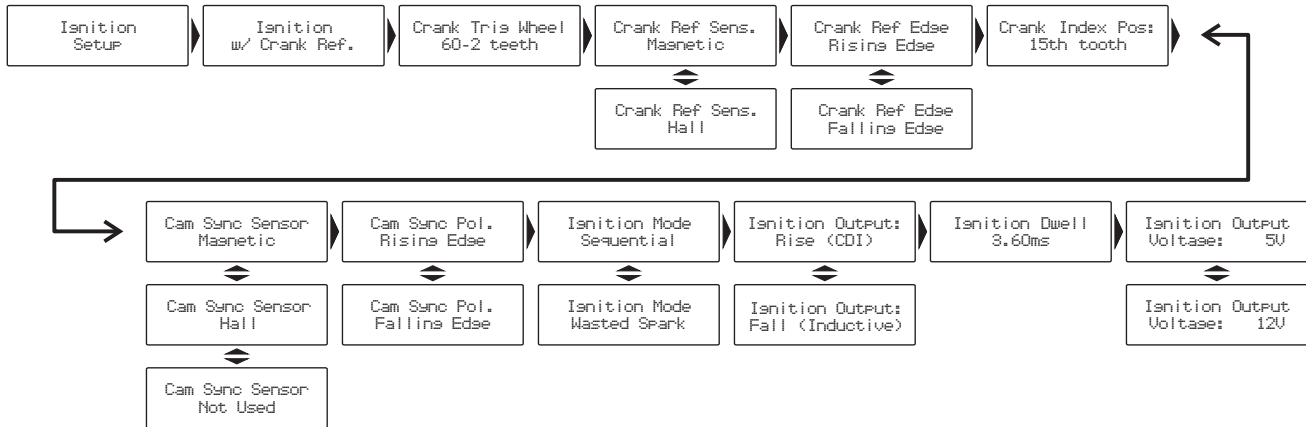

Crank Trigger	Engines/Brand	Possible Index	Ignition Calibration	Camshaft Position Sensor
60-2	BMW, Fiat, Ford (Marelli ECU), Renault, VW, GM	9° to 20° tooth	20° (GM) see OBS. 15° (others)	Not mandatory
36-1	Ford (FIC ECU)	5° to 10° tooth	9° tooth	
36-2	Toyota			
48-2		3° to 10° tooth		
30-1				
30-2				
24-1				
12-1	Motorcycles Honda/Suzuki/Yamaha	0 to 210°	60°	Falling edge
12	Motorcycles/AEM EPM			
24		55 to 90°	90°	
2	4 cylinders			
3	6 cylinders			
4	8 cylinders		45°	

Camshaft position sensor: in this parameter, the user must inform if the camshaft position sensor will be used and its type (Hall or inductive). The camshaft position sensor is necessary to control the ignition in a sequential mode; when not used, the ignition will always work based on a Wasted Spark system.

Ignition mode: when the camshaft position sensor is used, two options can be selected in this parameter. In “Sequential”, the individual coils will be switched in a sequential mode. In “Wasted Spark”, the ignition coils will work two-by-two.

Camshaft signal edge: this configuration informs if the signal from the camshaft position sensor is positive (standard) or negative (inverted) when the tooth passes by the sensor.

- Ignition output:** select the ignition type to be used:
- Fall (inductive): for modern inductive ignition modules, such as the 3-wire Bosch coil, SparkPRO-1 or coils with integrated ignition module.
 - Rise (CDI): it is used for capacitive discharge ignitions type MSD 6A, 6AL, 7AL2, Crane, Mallory and similar others.

Ignition dwell: it is the coil's charge time, measured in milliseconds. An adequate charge time for most regular coils and ignitions is between 3.00ms and 3.60ms.

Ignition output voltage: select the ignition coil's switching voltage. Most coils are switched with 12V. See the table in chapter 7.2 and check if there is any specific note about the type of coil being used.

Ignition with distributor and crankshaft trigger wheel

When the ignition is configured as Distributor/Crank Reference, there is a trigger wheel supplying the engine position information, but the spark distribution will be done by a distributor and a coil. When using this configuration, only the ignition output "A" is active and it will send pulses to the coil, while the other outputs will be disabled.

This configuration is similar to the one in the previous chapter regarding to "Ignition with Crankshaft Trigger Wheel", but, in this case, ignition happens in a sequential mode. The camshaft position sensor is not used.

10.3 Third step – generate FuelTech default setting

When the menus "Fuel Injection Setup" and "Ignition Setup" are properly adjusted, it is possible to create a "FuelTech Standard Setting", a set of basic injection and ignition maps that will serve as the basis for the operation of most engines. After this step is completed, a fine tune on the maps must be done.

When generating a standard map, some information is necessary:

Set A fuel injectors or fuel injectors: the flow rate of the fuel injector set that work since idle speed must be informed.

Initial pressure of set B: if the injection mode selected is "independent" and the Main Fuel Table is "aspirated by MAP" or "turbo by MAP", the Initial Pressure of Set B will be requested. This parameter is relative to the pressure in which the Set B starts to be activated, usually in the turbo phase.

Camshaft: the characteristics of the camshaft installed in the engine must be informed. When selecting high profile camshaft, all injection times from absolute vacuum until -4,3psi are equal, as this type of camshaft does not have steady vacuum at idle speed. When selecting low profile camshaft, the injection times at vacuum phase are filled up in a linear manner.

The ECU will display a warning to inform that the current configuration will be erased. The user must confirm in order to create the "FuelTech Standard Settings". All values in the injection and ignition tables will be overwritten.

"FuelTech Standard Setting" is an automatic calculation of the basic injection and ignition tables for the engine, based on the information inserted in the "Fuel Injection Setup" and "Ignition Setup" menus. When going through this automatic adjustment, all the injection and ignition tables (including compensations based on temperature, etc.) will be filled out based on the informed characteristics of your engine.

Therefore, the information inserted in the Injection and Ignition Setup menus must be correct and coherent, the maximum values of RPM and pressure must be in accordance with the engine capacity, and the fuel injectors must have been properly dimensioned based on the engine estimated power.

The FuelTech Standard Setting requires that the fuel pressure is set as a fixed 1:1 differential value starting at 43psi, so that for each 14.5psi of turbo pressure, the fuel pressure increases 14.5psi.

This standard map should be a basic reference for engine tuning only, and the user must be very careful, especially in the beginning, as, even though it is an adjustment that will start most engines, there is no guarantee that it is proper for every load situation. Be very careful when tuning your engine. Never put load on an engine before it is perfectly tuned.

Also, it is very important to use an instrument to analyze the air-fuel mixture, such as a regular lambda probe or a wide band lambda probe (recommended), pyrometer and/or an exhaust gas analyzer tool.



NOTE

The parameters to configure Fuel Injectors and Camshaft will only be displayed if the option "injection by MAP" has been selected. If the injection map has been set by TPS, information for these parameters will not be requested. Only when the set of injectors are configured as independent, there will be an option to select when the Set B must start injecting.

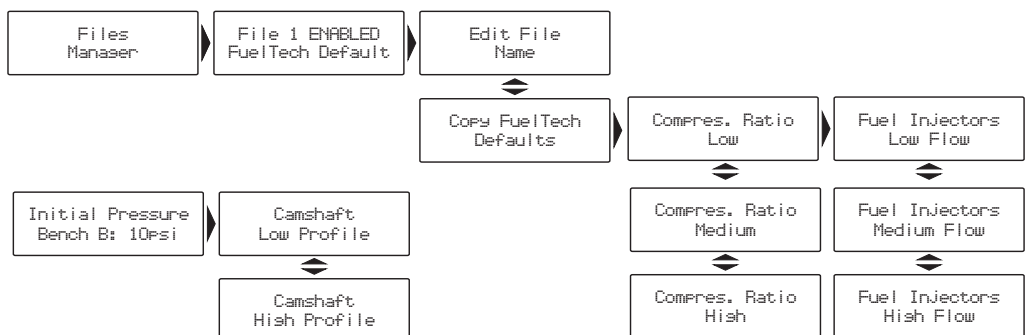

10.4 Fourth step – sensors check-up and throttle position sensor (TPS) calibration

With this option it is possible to check the connections of all temperature and pressure sensors used with the fuel injection system. The TPS sensor can also be checked and calibrated through this menu.

The Ignition Calibration will be detailed in the chapter 11.1 in this manual.

The TPS sensor installed with the injection must be calibrated in the first time the injection is operated, and calibration only needs to be redone if the sensor is exchanged or if its course has been dislocated. This calibration is not erased when the car battery or the ECU are disconnected.

To calibrate the TPS:

1. Enter the TPS calibration function. The display will show either "TPS: Press (↵) to Calibrate" or "TPS: Calibrated".
2. When pressing the right button, the "TPS Idle Speed" position will be requested. Leave the throttle pedal at rest and confirm.
3. Then, "TPS Full Throttle" will be displayed. Press the throttle all the way and confirm with the right button.
4. The message "Calibrated!" will be displayed if the process was successfully finished.
5. If an error message is shown, check the TPS wiring connections, as well as its connector.

The errors on TPS calibration can be:

Inverted and calibrated: it informs that the TPS has been connected in an inverted manner, but it has been successfully calibrated. It would be ideal to check its connection, but it will work anyway if kept as it is.

Possibly disconnected: Check TPS connections. If it is correct, it is possible that the TPS wiring order is incorrect.

To verify and correct TPS connection errors or reading interferences, test the system as follows:

With a tester set at a 20k ohms scale, disconnect the module's cable and leave the ignition turned off. Start the measurements between the Green/Red and Black wires from the connector: the resistance must not vary when accelerating. If it varies, invert the wires in such a way that the TPS resistance varies only between the Orange and Green/Red wires, and Orange and Black wires. TPS signal voltage must rise according to the opening of the throttle. If the ECU displays the message "inverted", all it is needed is to invert the Green/Red and Black wires at the TPS and recalibrate.

If any sensor is shown as "disconnected", check its connection to the ECU, to the battery's negative terminal and, lastly, check if it has not been damaged. To verify if the cable that goes to the injection is not broken, the temperature and pressure sensors input may be connected to the battery's negative terminal, which means maximum temperature and pressure. If the ECU is not able to read it, the cable might be broken.

11. Starting the engine for the first time

The chapter 10 in this manual provides orientation to the user about all the necessary configurations that must be done prior to starting the engine for the first time. Only proceed in this chapter if you have already read the manual thoroughly up to this point. This will facilitate the understanding of the information in the following chapters.

If there is any difficulty starting the engine for the first time, especially in cars using ethanol or methanol, inject a little gasoline.

If the engine shows that it is difficult to start because of too advanced timing, retard the distributor or change the ignition timing at start (only with trigger wheel). In the case of trigger wheel use, verify if the alignment of the trigger wheel is correct. Also, carefully check if the ignition order is not incorrect because of an inverted ignition cable or coil connection.

When the engine starts, keep it at idle speed and be attentive to the temperature of the ignition coil and the ignition power module. If it heats rapidly, turn off the engine immediately and decrease the ignition coil's charge time. As a suggestion, the user may want to wait for the temperature to cool down before starting the engine again.

Carefully check if RPM is correctly shown by the injection (with an external tachometer) and if the variations in the throttle match with the value displayed for the TPS and the vacuum readings in the dashboard screen. If strange RPM values are noticed, it certainly means that interferences are occurring when the signal is captured.

11.1 Ignition calibration

As soon as the engine starts, before any adjustment, the ignition calibration must be done. This calibration is to make sure that the timing is happening as expected and it is reaching the engine properly. If the distributor position or any ignition configuration is not right, the ignition timing will be applied incorrectly. With the use of a timing light, it is possible to check the calibration.

The ignition calibration function locks the ignition timing applied to the engine at 20 degrees at any given RPM; therefore, if the engine starts and does not maintain at idle speed, it can be accelerated to any RPM and have the calibration done.

The RPM can stay at any value, as long as it is kept with the minimum variation possible, as it may cause errors in the timing light readings. When RPM is stabilized, enter the "Ignition Calibration" option, in the "Sensors and Calibration" menu.

Calibration of Ignition with distributor

When entering the Ignition Calibration function while using an ignition with distributor, the ECU will display a blinking message that reads: "CALIBRATE DISTRIBUTOR WITH 20°", as shown in the image below. While this message is being displayed, point the timing light to the mark on the flywheel.

In engines equipped with a distributor there is a TDC on cylinder 1 mark at the flywheel and the engine block. Point the timing light to this mark and turn the distributor until the timing light reads 20°. Fix

the distributor, and the calibration is completed.

Calibration of ignition with crankshaft trigger wheel – FT250

FT250 can control ignition through a crank trigger, the use of a FirePRO or Fire4S is needed. Check their instructions manual for more information.

Calibration of ignition with crankshaft trigger wheel – FT300

Cars that are originally equipped with a trigger wheel from the manufacturer don't usually have a mark that indicates the TDC on cylinder 1. To calibrate the ignition, this mark must be done at the flywheel or the engine block.

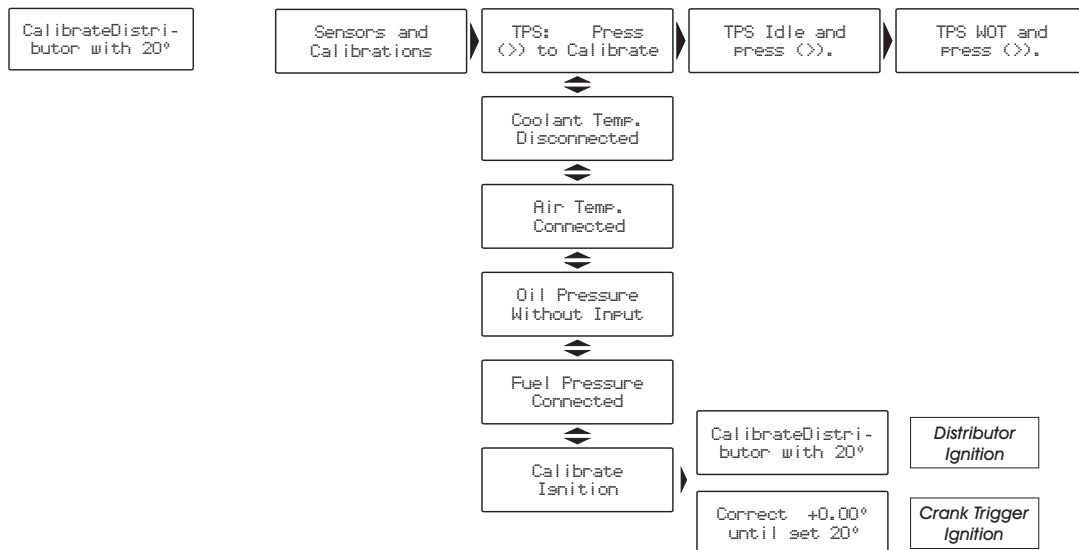

When entering the Ignition Calibration function, the screen below will be displayed.

This function allows the user to correct the ignition timing directly in the module, as, differently from the distributor, it is not possible to dislocate the trigger wheel.

If the timing read was 24°, the user only needs to configure a correction of -4° so the timing at the timing light becomes 20°. If it indicates a timing with a difference greater than 10°, it is very likely that the alignment of the trigger wheel has been incorrectly informed in the "Ignition Setup" menu.

When the ignition is controlled by a trigger wheel, the ignition system usually works on Wasted Spark, meaning that there are two ignitions per cycle in each cylinder, one at combustion time and another at exhaust time. As the timing light captures both ignitions, it will read the engine timing as 40°. If the timing light does not have a wasted spark mode, the calibration with 40° is correct; otherwise, the correct reading in the engine should be 20°.

In wasted spark, if the timing read in the engine is 46°, for example, the correction applied should be -3°, and not -6°, as its value is doubled.

12. Fuel injection tables adjust

12.1 Main fuel table (load)

The amount of fuel injected is measured by the time variation in which the injector is kept open every RPM cycle. At every engine RPM, the fuel injectors open twice, and are kept open for a period of time called "Injection Time", set on the main fuel table. This time is measured in milliseconds (a thousandth of a second; for example, 3.44ms means 0.00344 seconds).

To tune the engine, the injection time values for each interval of engine load are informed (engine load can be represented by the throttle position (TPS) or by the vacuum/pressure in the manifold). Such information is used to constitute the table that will be used as a basis for compensations and, then, determine the exact injection time.

Notice that at intermediate points between the values found on the table, the system runs an interpolation of data. For example, if the map has been adjusted to inject 1.00ms at 10% TPS and 2.00ms at 20% TPS, when the throttle is exactly at 15%, the injection time will be calculated based on the line that connects the 2 points, which is,

in this case, 1.50ms, exactly. The interpolation is done within 0.25% of TPS variation, and 0.01ms of injection time variation.

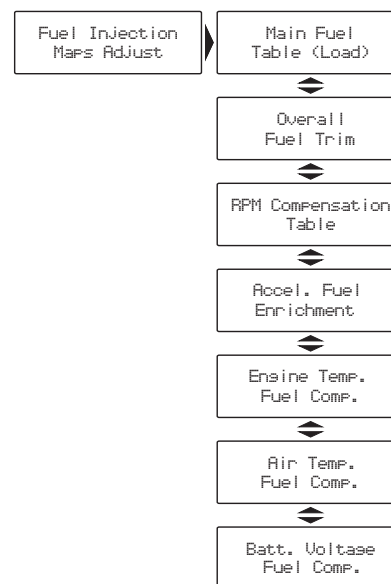

When the option "Idle Speed by TPS" is selected, it means that when TPS is at 0%, injection time will be determined by the value found in the "Idle Speed" field on the "Main Fuel Table", and all the values for injection time by MAP will be disregarded.

The injection time at Idle Speed will be displayed at first on the Main Fuel Table, as shown in the image below.

The main fuel table can be displayed in 6 different ways, according to the type of engine and the injection mode selected in the "Fuel Injection Setup" menu.



Aspirated by TPS

This configuration is used to control an aspirated engine that, because of tuning, has high vacuum variations at idle speed and low RPMs. In this setting, the engine vacuum is totally ignored for injection time calculation purposes.

This map represents the amount of fuel that must be injected in each throttle situation. The adjustments in this map can be done with a static TPS in all conditions, varying RPM only, preferably with a dynamometer. Using independent fuel injector sets, the main fuel table of a car aspirated by TPS is as shown in the image below:

Aspirated engines can use independent fuel injector sets when one wishes to use fuel injectors with a lower flow rate, having one set for low charge situations and another set for when a greater charge is requested from the engine.

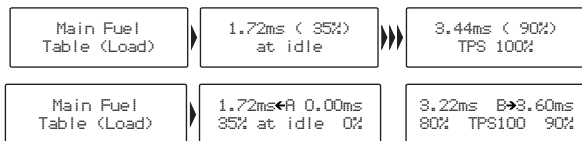

Aspirated by TPS/MAP

In this configuration, the Main Fuel Table is done by TPS, as in the previous option, but it is possible to apply a percentage compensation on injection times according to MAP (engine vacuum). The Main Fuel Table by MAP goes from -13psi to -3psi, with -2psi intervals.

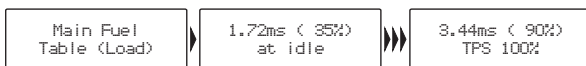

Aspirated by MAP

This configuration is used to control an aspirated engine that has steady vacuum, usually engines with original characteristics or less tuning.

This map represents the amount of fuel that must be injected based on the vacuum readings in the intake manifold. It is the best representation of engine charge, as it is independent from air intake limitations, or variations in RPM and charge situations.

Using independent fuel injector sets, the main fuel table of a car aspirated by MAP is as shown in the image below:

It is possible to individually control the fuel injector sets, according to the vacuum in the manifold in any given situation.

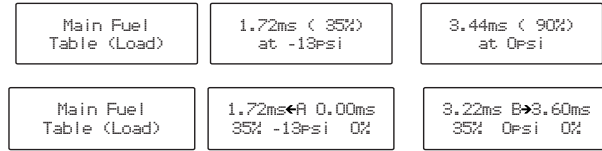

Turbo by MAP

This configuration is used to control engines that will operate with positive pressure (turbo, blower, etc.). It starts at the injection time of the idle speed vacuum (usually between -12psi and -7psi), and goes up to the maximum turbo pressure used.

This map represents the amount of fuel that must be injected based on the vacuum and pressure readings in the intake manifold.

The intervals between each point on the table are:

- On vacuum ranges: 0,2psi.
- On positive pressure ranges up to 29psi: 0,3psi.
- On ranges above 29psi: 0,5psi.

Using independent fuel injector sets, the main fuel table of a car with turbo by MAP is as shown in the image below:

Maps of turbocharged engines usually use independent fuel injector sets, as the Set A is normally used for idle speed and low charge, being complemented by the second set when the boost pressure starts rising. It surely allows a better tuning, as it is possible to keep the original injectors on Set A and use injectors with a higher flow rate on Set B.

Generally, there is one fuel injector per cylinder on Set A put next to the cylinder head, and the Set B has other fuel injectors that will be driven when the first set comes near its limit. Set B may usually be arranged with one fuel injector per cylinder at the intake manifold, or other fuel injectors at pressurization.

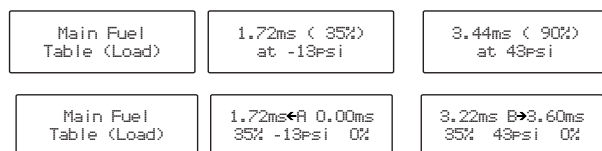

12.2 Overall fuel trim

The quick settings function recalculates and substitutes all the values in the main fuel table according to the desired setting. It can be accessed through the "Fuel Injection Tables Adjust" menu or through a shortcut on the dashboard screen, pressing the right button for 2 seconds.

When the independent injection mode is being configured (2 independent sets of fuel injectors), the system will request this quick setting to be done for each one of the Fuel Injector Sets.



Compensation applies a multiplication index to the previous values in the map. For example, if at pressure 14.5psi (for a Turbo by MAP), 2.00ms was being injected, which is equivalent to 50% of fuel injector opening at maximum RPM, and a compensation of +10% is applied, the point on the table will become 2.20ms and 55% of fuel injector opening (and not 60%, as one could mistakenly suppose).

For all compensations applied, fuel injector dead time is considered

in order to have a compensation that refers to the real amount of fuel injected, and not the fuel injector opening signal.

12.3 RPM compensation table

The fuel injection map based on RPM is a percentage correction map, which means that these percentages will be applied to the injection times in the main fuel table. The calculation of the injection time is automatically done according to the current engine RPM and to other compensations configured. Therefore, it is not necessary to have a table for each RPM scale, which, although more precise, it is time-consuming, and when it is not corrected with a dynamometer, it hardly brings any final improvement.

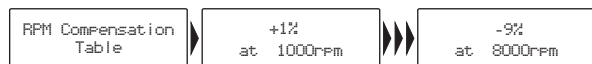

By using a percentage compensation, it is possible to adjust the injection of any type of engine, be it an original engine, an engine with a more aggressive valve timing control or with variable valve timing control system (such as Honda's VTEC, Toyota's WTi, BMW's VANOS, etc.).

12.4 Acceleration fuel enrichment.

Acceleration Fuel Enrichment is an increase in the fuel injection when there is a quick throttle variation.

Maximum pulse on pump: it is the value that will be added to the current injection time when a quick throttle variation occurs.

TPS variation for max pump: in this configuration, one must inform the TPS variation to which the maximum pulse must be applied. Consider, for example, a car running with only 10% of TPS. Suddenly, this value rises to 50%. The TPS variation was 40%. If the value configured in this parameter is 40%, the maximum pulse will be applied, which means that 4.00ms will be added to the injection time currently applied to the engine. If the variation was only 20% of TPS, the maximum pulse would not be injected, as it had not reached the value configured in this parameter.

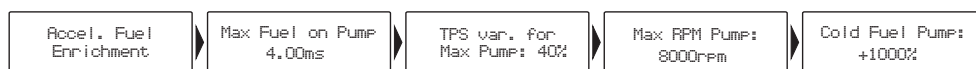

12.5 Engine temperature fuel compensation

This compensation is applied based on the engine temperature sensor, which, in water-cooled cars, must be at the cylinder head reading the water temperature, and in air-cooled engines, must be reading the oil temperature. Compensations based on engine temperature are only available when the sensor is connected to the injection system. Engine temperature greatly influences the amount of fuel requested by the engine, especially in cars run with ethanol and methanol, when it is possible to operate a cold engine as if it had already reached normal temperatures.

All engines have its specific consumption peak at the maximum torque RPM. Therefore, it is in this range that a positive compensation of about 5% to 15% must be applied. Such RPM on a regular engine with original valve timing control is usually between 2000rpm and 4500rpm. It is only possible to know the exact RPM with a dynamometer. In real situations, the compensation will be automatically executed by the tuner, as, in order to maintain the lambda at a constant level, the maximum torque RPM will require more fuel.

With the injection map based on charge and this injection map based on RPM, the injection system internally creates a 3-dimensional map of Injection x Charge x RPM, which is automatically applied to the engine.



IMPORTANT
Always verify the continuity of the data. Avoid incoherent values or values that will result in graphs with abrupt variations. Any feed, in order to be efficient and correct, must necessarily form graphs with smooth lines.

Small throttle valves usually need a large TPS variation to inject the acceleration fuel enrichment total pulse (greater values are used, such as 90% of TPS, for example). On the other hand, when using throttles with a large diameter, a very small TPS variation is already enough to reach the quick maximum pulse (smaller values are used, such as 15% of TPS, for example). When a TPS sensor is not used or when maps are configured based on MAP readings, the MAP variation is the one considered for this setting.

Maximum RPM pump: this parameter is used to limit the RPM, above which acceleration fuel enrichment will not be applied.

Cold fuel pump: increase of acceleration fuel enrichment when the engine is cold, which is extremely necessary in the first minutes of engine operation, especially in engines run with ethanol or methanol.

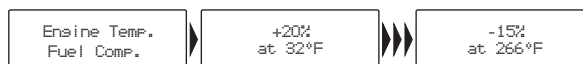

12.6 Air temperature fuel compensation

This compensation is applied based on the air temperature sensor placed in the intake manifold, and it is only available when the sensor is connected to the injection system. This compensation mode is used to automatically adapt the injection to different temperatures of the air taken by the engine. In turbocharged engines, it is of great importance, because when the system is pressurized, the temperature rises immediately to very high numbers. In cars with intercooler, the ideal mixture can be used from intercooler inefficiency situations (low speed) on.

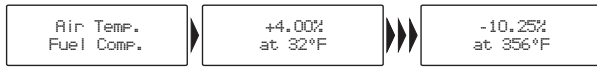

12.7 Battery voltage fuel compensation

This compensation is applied based on the vehicle's battery voltage and it takes into consideration that the decrease in fuel injectors' feed voltage influences their opening time. It is a subtle compensation, but very useful in cases when there are great voltage variations caused by the lack of an alternator, for example.

Fuel injectors with a high flow rate usually operate with minimum injection time at idle speed and are the ones most affected by a drop of battery voltage, as a variation in their dead time occurs, which may lead to an injection glitch, meaning that the fuel injectors may not work as a result of voltage drop. By using this compensation, such problem is avoided.



13. Ignition tables adjust

It is very important to notice that all maps can advance or retard the timing established in the main fuel table, and that when a "FuelTech Standard Setting" is generated, all maps will be filled out with standard values. Therefore, if you wish the ignition timing to be established only by the Main Ignition Table based on RPM, you must manually erase all ignition tables based on Pressure/TPS, Engine Temperature and Air Temperature back to ZERO.

13.1 Main ignition table (RPM)

The Main Ignition Table based on RPM is a table in which the main ignition advance curve is indicated by inserting the desired ignition timing at every 200rpm up to the RPM limit.

For example, if one wishes to have an initial timing at 15° and a final timing at 32° (as it is done with a distributor), the values inserted in the table must be 15° at 600rpm, 17° at 1000rpm and so on, gradually, until reaching the 32° at, let's consider, 8600rpm, as the final timing

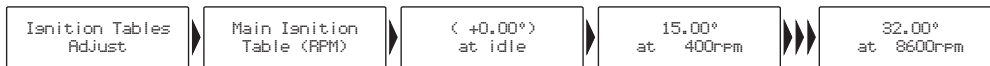

13.2 Overall ignition trim

To apply a correction quickly to the entire ignition map, the Overall Ignition Trim function may be used. It is only necessary to inform the correction, negative or positive, and confirm by pressing the right button. This correction will be added to or subtracted from the entire ignition table based on RPM.

This function is very useful in critical situation when one wishes, for example, to quickly retard the ignition timing because of a problem, or when one wishes to be a little bolder about the ignition timing in search for a better performance.

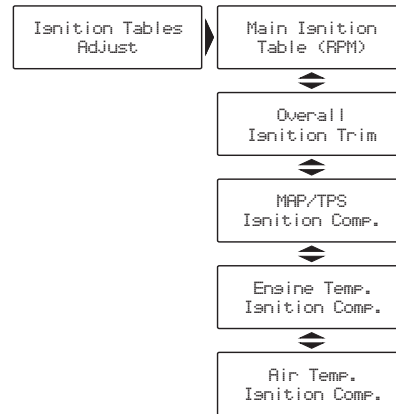

point. In a different situation, if one wishes to have constant ignition timing at 24°, for example, all fields in the table must be filled out with 24°.

Notice that for ignition timing to be applied exactly with the values established in the ignition map it is necessary to erase all compensations based on air and engine temperature, pressure, etc back to zero.

13.3 MAP/TPS ignition compensation

A map based only on engine RPM does not provide maximum efficiency in all engine's power ranges. For example, a turbocharged engine requires more retarded ignition timing when working with

positive pressure than when working on aspirated phase. Without a retard based on pressure, one would have to keep the entire ignition timing retarded to have a good performance under charge, but in opposite situations it would lack ignition advance, thus, decreasing torque and power.



When the module is configured to control an aspirated or a turbocharged engine by MAP, the engine charge compensation map is

based on pressure, starting from a compensation value at idle speed, up to the maximum turbo pressure (image above).



When the module is configured to control an aspirated engine by TPS, this map is based on throttle position (TPS), as it represents the load that is being requested from the engine, and with that information it is possible to define the points of greater advance and retard in the ignition timing (image above).

It is a very important feature and it brings significant improvement on drivability, especially while operating cold engines, when advanced ignition timing is necessary in order to have a correct response from the engine. It is also essential for engine protection, as it retards the ignition timing when the engine reaches high temperatures.

13.4 Engine temperature compensation

This map represents a compensation on the advance or retard angle applied to the main RPM map based on engine temperature variation.

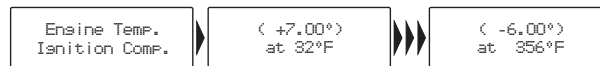

13.5 Air temperature compensation

This map represents a compensation on the advance or retard angle applied to the main RPM map based on intake air temperature variation. It is beneficial, because the colder the air entering the combustion chamber, the denser it is, and the greater the possible ignition advance is. But when temperatures are very high (especially

on turbocharged engines), the ignition timing must be retarded to protect the engine.

It is a very helpful feature, particularly when the engine is exposed to great variations of air temperature caused by weather changes, or variations of intercooler or ice cooler efficiency, for example.

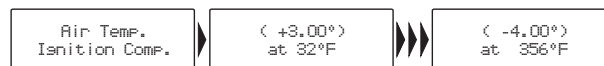

14. Auxiliary functions adjust

This menu allows the adjustment of all functions that modify the operation of auxiliary outputs and compensations of engine start, idle speed, etc. Some functions depend on previous configurations

of an auxiliary output for its proper operation. The following message will be displayed if the accessed function has not been configured to an auxiliary output yet. For this configuration, enter the "Input/Output Setup" Menu and set up the selected output.

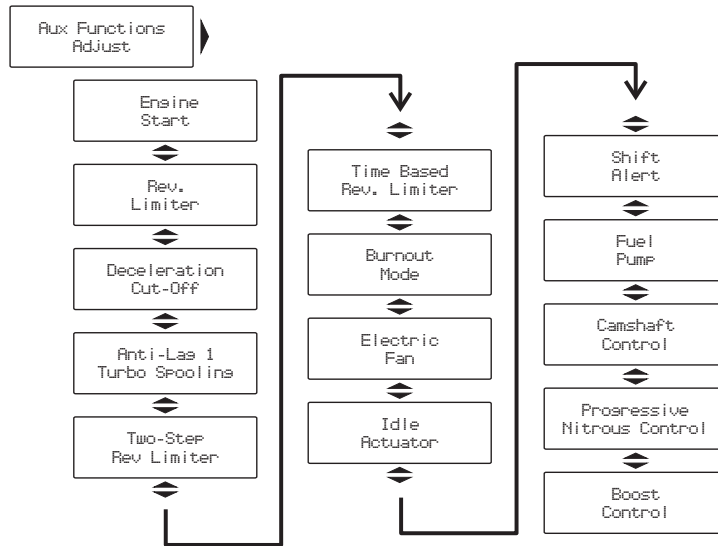

14.1 Internal datalogger

This function is used to log all the engine data read by FuelTech ECU. To view the internal log you just need to download the software FuelTech Datalogger (www.fueltech.net), and connect the ECU to the computer with the FuelTech USB/CAN Converter.

The Internal Datalogger can record up to 24 channels like: injection time (banks A and B), injectors duty cycle (banks A and B), timing, engine rpm, auxiliary output status, TPS, coolant and air temperature, oil and fuel pressure, O2 sensor, two-step button, MAP sensor, camshaft position sensor and battery voltage.

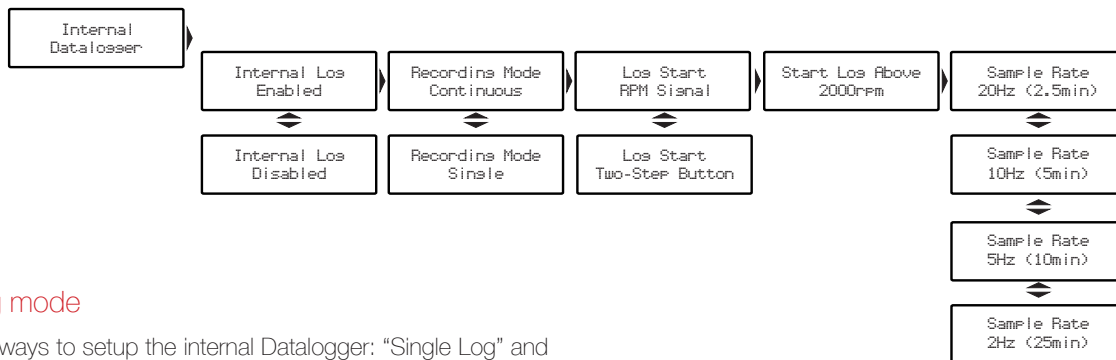

Recording mode

There's two ways to setup the internal Datalogger: "Single Log" and "Continuous Log".

Single log: the ECU logs until memory is full, after that, data logging is stopped and the log is stored. It is necessary to download the log file to a PC using a FuelTech USB/CAN Converter and the FuelTech Datalogger software.

Continuous log: in mode the ECU is continuously recording engine data. When memory is full, the log is overwritten. In this manner, you always have the last minutes of engine data recorded on the internal log.

When choosing by "Two-Step Button", the log will start when two-step button is pressed.

The recording can only be stopped when the memory is full (Single Log) or when the ECU is shut off (Continuous Log/Single Log). Remember that if the ECU is turned on again, data will be kept only until a new log is started (programmed rpm reached or two-step button pressed), in this case, previous log will be overwritten.

Log start

There's two ways of starting the log: RPM signal or Two-Step button. When selecting "RPM Signal", the log will start only when the adjusted rpm is reached by the engine. The rpm setup menu will only be shown when selecting this option.

Sample rate

The sample rate defines log quality. Higher the sample rate, more detailed is the log, however, the logging time will be short. For competition vehicles, especially drag racing, it is recommended to use a high sample rate to have high detail level on the log.

Internal datalogger status

At the Dashboard Screen of the ECU, a screen containing info about the Internal Datalogger is shown. Below is this information explained:

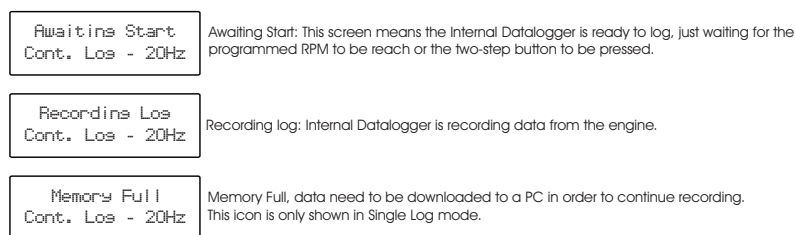

14.2 Engine start

By using 3 parameters in this function, it is possible to define perfectly the curve of the engine start injection based on engine temperature. Whenever the RPM drops below 600rpm, the injection applies start injection pulses in addition to the idle speed value. This excess of fuel prevents the engine from falling involuntarily, making it return to idle speed. Be careful not to exaggerate on injection time, as it may cause the engine to choke easily.

The engine must always be turned off through the injection system. Otherwise, if RPM drops below 600rpm and injection is turned on, the system injects fuel that will not be burned and, therefore, will be accumulated on the cylinder. For that reason, it is ideal to install the injection along with the vehicle's start key. If the engine temperature sensor has not been installed, only the value from start injection with cold engine is considered. When operating on Simultaneous Injection Mode, both injector outputs injects at the start; but when operating on Independent Injection Mode, only the injectors set A pulses at the start.

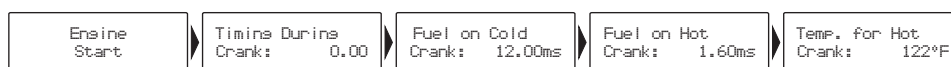

14.3 Revolution limiter

This function is very important for engine protection, limiting the RPM with three different options of cut-off:

Fuel only: only the fuel injection is cut-off instantly, as the ignition is still operating. It is a very smooth and clean cut-off. Recommended only for low-power engines, it is the standard setting in vehicles with original injection systems.

Ignition only: the engine ignition is cut-off when the configured RPM is reached. It is recommended for high-power engines, especially turbocharged ones, being the most efficient and safe option.

Ignition & fuel: at first, the ignition is cut-off, and after a configurable tolerance of few RPMs, the fuel is also cut-off. When using this option, problems with excess of fuel during the cut-off are avoided, diminishing its damaging effects.

RPM may cause the engine to turn off involuntarily during deceleration. On the opposite case, when setting a very high RPM, there will not be significant fuel economy. The "Cut-off Delay for TPS=0%" parameter is the time (in seconds) counted before fuel is actually cut-off after releasing the throttle. Such delay exists to prevent the engine from instantly becoming lean when the throttle is released. It also rapidly cools the combustion chamber without being excessive, and avoids situations in which the cut-off might oscillate, especially when the throttle is lightly pressed. A standard delay of 0.5s is suggested.

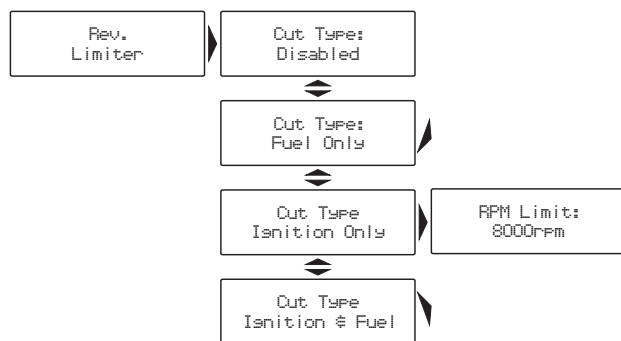
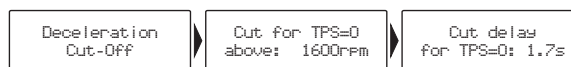

14.5 Anti-Lag – turbo spooling

Turbo lag is a time delay on the spooling of the turbine to maximum efficiency. This is usually common in engines with turbines sized for extreme power levels and that take some time to start at low RPMs, when the engine does not have enough exhaust energy to properly spool the turbocharger. The Anti-Lag function is used to improve the process of filling up the turbine housing with exhaust energy, generating a retard on ignition timing and an enrichment of the mixture above what has been set on the base map.

Retarding the timing, along with the mixture enrichment, makes the exhaust temperature increase, and, consequently, reduces the turbine lag.

14.4 Deceleration cut-off

This function cuts-off fuel every time the throttle is not being pressed and the engine is above the chosen RPM. A standard RPM of 2000rpm is recommended. Setting a very low

It is important to notice that a high timing retard and a high level of enrichment may result in an much accentuated loss of power, which is the opposite effect of what is expected. It is recommended to use a retard value around -5 degrees and fuel enrichment lower than 10%.

The Anti-Lag function is activated when TPS is above 95% and the boost is within the limits set in the system. In the example above,

once the system identifies that TPS is above 95% and the pressure is between 3 and 9psi, the ignition timing is retarded by 5 degrees, and the fuel injection is corrected by 8%.



14.6 Two-step rev. limiter

The two-step function is activated when the blue input is connected to the battery's negative terminal. When pressing the two-step button, (usually installed on the steering wheel), the system activates an ignition cut at a programmable RPM (generally between 3000rpm and 6000rpm), with a retarded ignition timing value (normally equal or

lesser than 0°), and a mixture enrichment given in percentage (also programmable).

When the car is stopped and the two-step is on, it is possible to spool the turbocharger to very high pressure levels, giving the torque needed by the engine and allowing the launch to occur with lower RPMs, and, consequently, having less loss of traction.

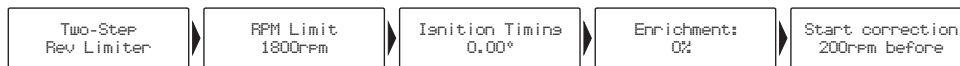

14.7 Time based RPM control

The RPM control is based on seven RPM points that can be determined as shown in the image above. This function is frequently used in drag racing cars, because it makes it easier to control the vehicle, once it

allows the traction to be recovered through an ignition cut ramp. It is a passive traction control, and therefore, some attempts must be made before finding the perfect adjustment, considering the characteristics of the car and the quality of traction provided by the track.

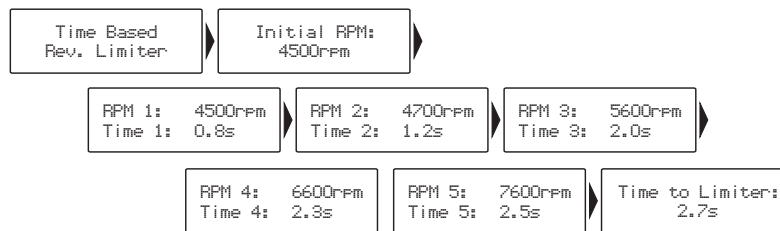

14.8 Idle speed by timing control

Idle speed by timing is based on stock ECUs, that vary the timing in order to change the engine rpm. A target rpm for idle speed is selected and the ECU advances or retards the timing in order to keep the rpm near the target.

Reaction level: the higher the value configured on this parameter, the more aggressive and with greater compensations the ECU will perform to advance or retard timing when trying to avoid the RPM to drop. Such value varies greatly according to the engine configurations; therefore, it must be adjusted as needed. A very high value may cause the idle speed to oscillate when RPM drops; the opposite will cause the engine to turn off when an extra charge is requested.

Timing limits for idle control: this values are limits for advance and retard when ECU is controlling the idle by timing.

Adjusting idle speed by timing: To start adjusting the idle by timing control, follow these steps:

1. Stabilize the idle speed rpm by using O2 sensor values a little richer than the stoichiometric (0,95 Lambda, 13,8 AFR (gasoline). Using a lean mixture on idle speed can cause the engine to shut off easily when extra load is required (A/C turning on or power steering, in example);

2. On the Main Ignition MAP start advancing timing, the idle will start to rise. Continue advancing timing until the idle stops rising. This timing value should be inserted in the Maximum Timing Limit parameter for idle speed. The Minimum Timing Limit should be set as -5°;
3. Enable the Idle by Timing Control, let the engine idle and check the timing at the ECU Dashboard. Usually, the best results are achieved with timing between 0° and 10° when idling. This way, the ECU has range to compensate if the rpm rises or falls;
4. If you notice that the timing is always working at the minimum or maximum programmed timing, you'll need to change the throttle position. If the timing is at the maximum limit, it may be necessary to open the throttle a little. Otherwise, if it's always working at it's minimum timing limit, you should close the throttle opening for idle a little bit.
5. The ideal work range for idle by timing is the medium point between Minimum and Maximum Timing.

It is vital to Idle by Timing Control that the engine is equipped with a perfectly working and calibrated throttle position sensor (TPS). This control only starts working when TPS=0% and is automatically disabled when TPS leaves 0% position.

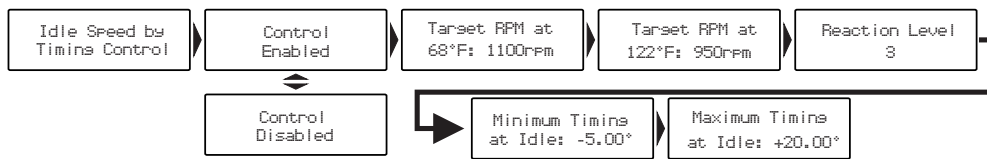

14.9 Burnout mode

The Burnout Mode is a function used to facilitate the processes of warming up the tires and using the two-step. When pressing the two-step button, the two-step function is activated. Once the button is released, the curves from the Time-based RPM Control come to action, allowing the tires to be warmed up properly.

When the Burnout Mode is activated, it prevents the RPM Control from being initialized, so its ignition cut configurations are the parameters considered by the system.

This function must be enabled through the "Input/Output Setup" menu.

Once enabled, press and hold the up button for 2 seconds on any dashboard screen. The message below will blink to indicate that the Burnout Mode has been activated.

When this message is blinking on the screen, the configuration set for the "burnout limiter" parameter becomes the value considered for the final ignition cut. But when the two-step button is being pressed, the value considered is the one set for the two-step parameter. The values adopted for ignition timing retard and enrichment are the ones configured on the two-step function.

After having warmed up the tires, the user only needs to press the up button for the injection to return to its standard operation mode.



14.10 Electric fan

The electric fan control in the engine cooling system is based on the temperature in which it is expected to be activated and disabled. One can establish that the electric fan must be activated when the

engine reaches 194 F and turned off when it cools to 180 F. At the "Input/Output Setup" menu, select the output that will be used for this actuator and, then, inform the chosen temperatures.

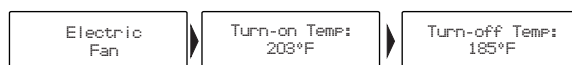

14.11 Idle actuator

This function activates an idle speed control actuator that opens only to increase the airflow to the engine, consequently increasing RPM. At first, select the auxiliary output that will switch the solenoid at the "Input/Output Setup" menu. Then, configure the parameters shown. To cover all possible situations, there are four configuration parameters and one enrichment setting:

- Turn-on actuator on crank: it is the time after starting the engine during which the actuator will be active. This parameter helps starting the engine and stabilizing idle speed after the start, which usually tends to drop, even when the engine temperature is normal.
- Turn-on under (Temperature): a temperature – considered to be the one in which the engine normally operates – is chosen. If the engine is below such temperature, the actuator is kept enabled.

This helps the engine to operate while cold, and, usually, the engine is not able to maintain a low idle speed.

- Turn-on under (RPM): an idle speed RPM – considered to be the minimum engine RPM – is set, so when the engine drops below that, the actuator is activated for as long as what has been set in the next parameter.
- Retest RPM every ("x" seconds): this is the time during which the actuator will be active; after elapsing, the actuator will be turned off. Such set up is helpful in situations when more load is put on the engine even if its operating temperature is considered normal, for example, when the electric fan or the air conditioner are turned on.
- Enrichment: it controls the mixture enrichment when the valve is opened.



14.12 Shift alert

When the engine reaches the RPM set in this parameter, the screen will display a blinking message ("SHIFT") indicating that gear must be shifted.

To switch an external shift light, it is necessary to configure an auxiliary output at the "Input/Output Setup" menu. If no auxiliary output has been configured as Shift Light, the message "Output not configured!" will be displayed. Even so, it is possible to set the Shift Light RPM on the screen.



14.13 Fuel pump

This output activates the fuel pump through the negative terminal, connected to a relay. When starting the ignition, it is activated for six seconds, and it turns itself off if the module does not receive any RPM signal. The relay must be adequate to the current needed to switch the fuel pump.

14.14 Variable camshaft control

This function allows the control of a variable valve timing control system (or a 2-gear automatic system). Select the output used to control the camshaft solenoid, and then, inform the RPM that the solenoid must be turned on.



14.15 Progressive nitrous control

This auxiliary output configuration gives access to setting the ratio for the fuel-nitrous mixture (or nitrous only) through the pulse-width

modulation (PWM) sent to the solenoids. The image below shows all the possible settings for this function:

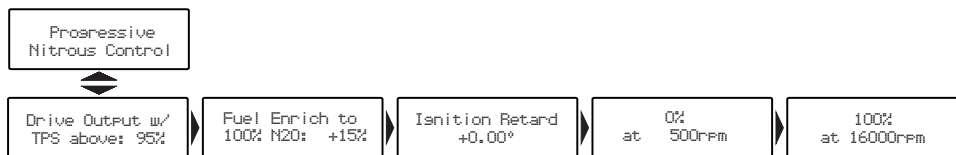

Configure an auxiliary output as "Nitrous" at the "Input/Output Setup" menu. Then, select the option "Progressive Nitrous Control" at the "Input/Output Setup" menu. The first parameter to be configured is the TPS opening percentage, above which the injection of nitrous will be activated.

Next is the nitrous injection map based on RPM. The highest the percentage configured in this map, the greater the amount of nitrous (or nitrous + fuel) injected. The maximum RPM is the same chosen on "Fuel Injection Setup". When using independent fuel injector sets, enrichment is done over both sets of injectors.

The next parameter is the percentage of fuel enrichment for 100% nitrous. Such percentage is applied to injection times, making them longer in order to keep up with the engine. The ignition retard is applied to the entire ignition table, which is necessary when there is nitrous injection.

The display below contains information about the Progressive Nitrous Control function shown on the injection's dashboard screen.

It is not possible to use Boost Control and Progressive Nitrous Control simultaneously, even when set up on different auxiliary outputs. If trying to do so, the message below is displayed:

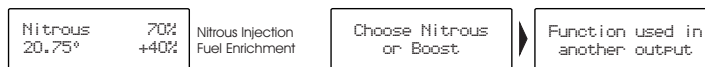

14.16 Boost control

To access the "Boost Control Settings", it is necessary to configure an auxiliary output to control this function, which can be done at the "Input/Output Setup" menu.

Select "LO for 0% Duty" when using a 3-way N75 solenoid, or any other solenoid that maintains the minimum boost pressure when inactive. This option is used in most cases.

This control allows the activation, through PWM, of a solenoid valve that controls the wastegate valve, therefore regulating the boost pressure. FuelTech recommends using a 3-way N75 solenoid. For more information about its installation, see chapter 8.7 in this manual.

Lastly, the maps are configured with the percentage of boost based on RPM, where 0% means that the valve is not activated and the boost pressure reached will be regulated by the valve's spring, and 100% means that the wastegate will be closed and the turbine will reach maximum pressure.

The first parameter to be configured is the TPS percentage, above which the Boost Control will start to pulse the control solenoid. When TPS is below the percentage set, the solenoid remains inactive, allowing the engine to reach the pressure adjusted on the wastegate valve's spring.

The screen below displays information about the Boost Control. It can be accessed through the injection's dashboard screen.

It is not possible to use Boost Control and Progressive Nitrous Control simultaneously, even when set up on different auxiliary outputs. If trying to do so, the message below is displayed:

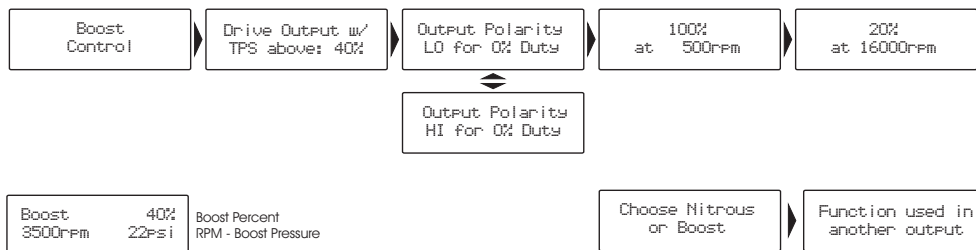

IMPORTANT

Be very CAUTIOUS when using this resource. When values close to 100% boost have been programmed, the turbine may generate full pressure, which may cause engine damage if it has not been properly prepared to support the pressure levels reached.

15. Input/Output setup

The "Input/Output Setup" menu includes some adjustments that are usually made by the tuner when installing the module and do not require subsequent modifications, such as the definition of installed auxiliary outputs and sensor inputs, for example. The auxiliary outputs must be previously configured in this menu in order to be accessible through the "Input/Output Setup" menu.

The inputs 1 (Blue/White) and 3 (Pink) are permanently set as air temperature sensor and engine temperature sensor, respectively. The input 2 (White) may be configured as oil or fuel pressure sensor. Finally, the input 4 (Blue) can be used as oil or fuel pressure sensor, or for the two-step button (activated by negative).

When a pressure sensor is selected in one of the outputs, it is also necessary to inform the type of sensor used. There are three types of pressure sensors: Siemens VDO (2-pin), PS-10A (3-pin and with "PS-10" written on its body) and PS-10B (3-pin, and with "PS-10B" written on its body).

The "Engine Protection by Check Control" function automatically turns the engine off in case any warning configured at "Check Control", under "Interfaces and Alerts", is reached. The engine can only be turned on again after the module is restarted.

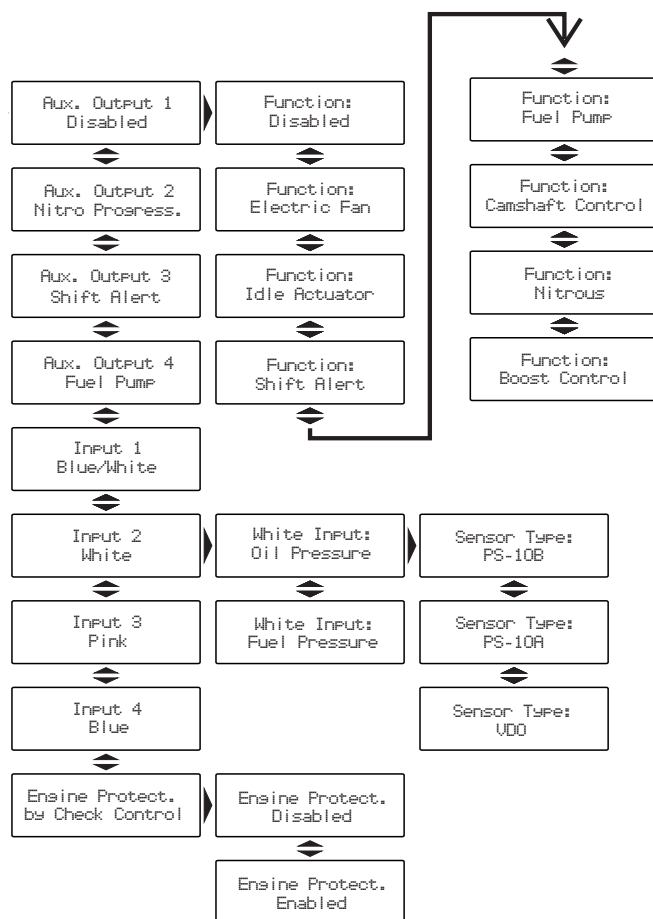

15.1 O2 sensor input

It is possible to record the O2 sensor readings in the internal datalogger using the White input. With the FuelTech USB-CAN Converter and the ECU Manager Software data can be downloaded and shown on a computer.

Electrical connection

Wideband O2 sensor: the use of an external conditioner is required (WB-O2 Meter Nano, Datalogger or Slim). The white input of the ECU

must be connected to the analog output of the conditioner (usually a yellow wire).

Narrowband O2 sensor: although these sensors have low accuracy when compared to wideband sensors, they can be recorded on the internal datalogger of the ECU, but, showing values in Volts.

Below there's a table with wire colors usually found in narrowband sensors:

As a general rule, if there are two wires with the same color, they are from the O2 sensor heater: one of them must be connected to a switched 12V and the other to the ground.

Wire color	O2 sensor 4 wires	O2 sensor 3 wires	O2 sensor 1 wire
Black	Signal	Signal	Signal
White (two wires)	12V after key and earth (on one in 12V and another on earth, has no polarity)		-
Gray	Battery negative	-	-

O2 sensor input configuration:

The configuration to read O2 sensors through the white input can only be done using the ECU Manager Software and the USB-CAN Converter. To download the software, go to <http://www.fueltech.net/softwares> and download the FuelTech software package.

Open the ECU Manager with the ECU connected to the USB port. Go to "Input/Output Setup > Inputs and Auxiliary Outputs". It is not possible to setup these options through the ECU screen. The menu to the right shows the O2 sensor type, its unit and analog input scale.

The input scale is defined according to the reading range of the conditioner. For WB-O2 Slim and Nano the standard scale is 0,65-1,30. The WB-O2 Datalogger can be setup in different scales, check which one is selected by connecting it to the USB and opening its software. Click "Edit Datalogger settings" button then go to "Datalogger properties" (as shown in the image).

Scale selection must match the scale used by the conditioner. For higher accuracy, select the lowest scale.

With narrowband sensors, its readings are shown in Volts (V) only in the internal datalogger (not on the ECU screen).

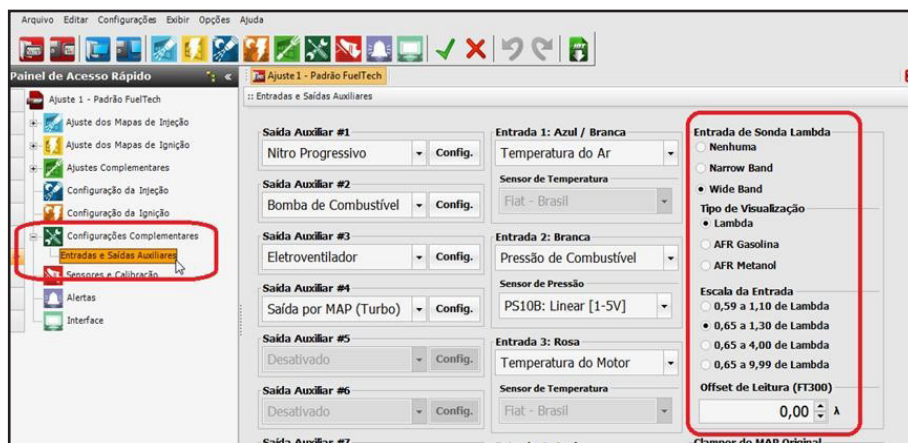

Reading differences

If experiencing differences between the value shown on the conditioner and the value recorded by the internal datalogger, make sure the input scale selected on the ECU matches the conditioner scale. Usually, a quick log is enough to determine, if values are matching.

If there are differences on all ranges of Lambda, adjust the parameter "Reading offset" on the ECU Manager Software to correct it. On the example below the reading offset was used to match Lambda values.

Software	Value (λ)
ECU (WB-O2 Slim and WB-O2 Datalogger)	0,85 λ
Value presented in the internal datalogger FT	0,95 λ
Offset	-0,10

**NOTE**

That the Reading offset is added/subtracted to the value recorded by the ECU internal datalogger.

15.2 MAP/MAF voltage clamber (exclusive FT250)

Wiring the clamber to the original ECU MAP sensor

When installing a turbocharger in an aspirated engine or increasing the pressure of turbocharged engines, some sensors from the original fuel injection control system display a failure alert. That happens because these sensors were not designed to read positive pressures. Electronically speaking, when MAP (or MAF) reads the turbo pressure, its output signal increases to a value with which the original fuel injection system is not used to working.

The FT200 integrated MAP/MAF Voltage Clamber must only be used if the original ECU is still controlling some feature of the car like electronic throttle, ignition, etc. and this feature is malfunctioning. When using FT200 all stand alone, there's no need to use the MAP/MAF Voltage Clamber.

The MAP/MAF Voltage Clamber wire is connected in parallel with the original ECU's MAP or MAF sensor's signal wire, preventing the sensor's output signal from surpassing what has been configured. In other words, the clamber "clamps" the signal from the sensor making it work only within the range in which it was designed to working. If the sensor signal rises above the configured maximum, the voltage clamber drains the exceeding voltage, therefore limiting its variation range.

Identifying the MAP/MAF sensor signal wire

The two images below show how to measure the wires from the sensor in which the clamber will be used. The wires must not be cut and, to avoid the insulation from being damaged, we recommend the use of a pin, as the tester leads can damage the insulation and the original wires' connector.

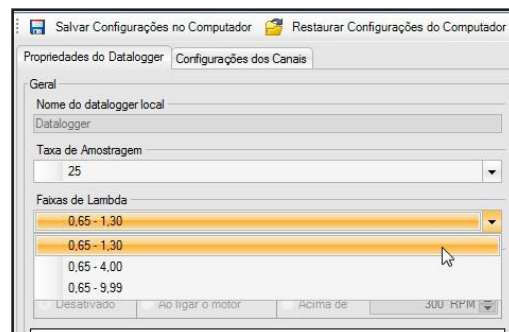
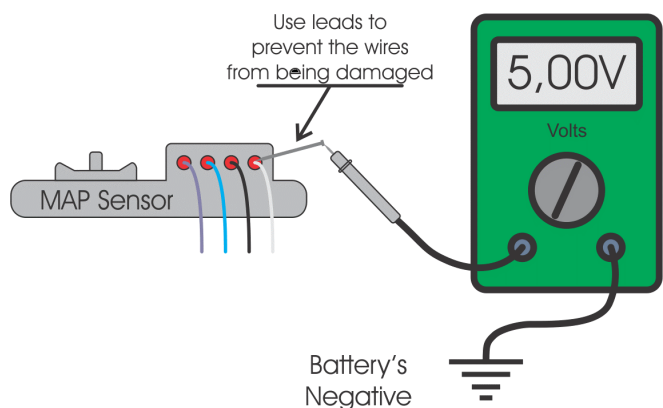

In order to find the sensor's signal wire, have the tester set to the 20VDC range and connect it as shown in the images above, one lead to the battery's negative terminal and the other lead to the sensor's wires. With the engine powered on, set the tester and accelerate. The voltage from the signal wire must range between 0 and 5V.

Then, connect the Green/Yellow wire to the sensor's signal wire.

The sensor's signal wire **must not be cut**. Just strip and splice it with the FT200 green/yellow wire.

Adjusting the MAP/MAF voltage

This menu allows the adjustment of the maximum voltage that the MAP/MAF Voltage Clamber will allow the original MAP/MAF sensor to reach.

MAP: After the voltage clamber wire is connected (set the clamber voltage to 5V), keep measuring the sensor's signal voltage with the use of a tester, but have the ignition key turned on and the engine powered off. The sensor will be measuring the atmospheric pressure and most likely the signal voltage will be at approximately 4.2V. Decrease the clamber voltage until the voltage read by the tester starts lowering. Usually, the value in which failures on MAP sensors are eliminated is a little lower than the value shown when the car is turned off. In this case, the ideal would be 4.1V.

MAF: To initiate the adjustment, it is recommended to have the clamber voltage at 3V and to drive the car. In order to define the clamber voltage, the operator must find the position in which the original fuel injection system no longer detects any anomaly in the sensor when the car is moving, both in full and low throttle.

Even when that position is defined, it is still possible to modify a little the position of the regulating screw. That is because the clamber, when limiting the sensor range, induces the original fuel injection system to exclusively read the vacuum, which means that the ignition curves will also vary according to the limit value set by the voltage clamber, therefore changing the engine's performance.

It might be interesting to carry out some tests in fine tuning this adjustment. Significant improvement on the engine performance can be obtained when the MAP/MAF Voltage Clamber is well tuned.

16. Interfaces and alerts

16.1 Check control

Check Control functions are warnings for dangerous situations, which can be programmed to emit a sound and visual alert. Through the “Engine Protection by Check Control” menu, under “Input/Output Setup”, the engine can be cut-off if any warning configured in the Check Control parameter is displayed on the screen.

Warnings can be individually configured for RPM excess, pressure excess, engine temperature excess, real saturation of fuel injectors, low oil pressure, high oil pressure, insufficient oil pressure above a specific RPM, low fuel pressure and incorrect fuel differential pressure. Anytime a warning is given by the injection, it emits a beeping sound and one of the texts below blinks on the screen until any key/button is pressed:

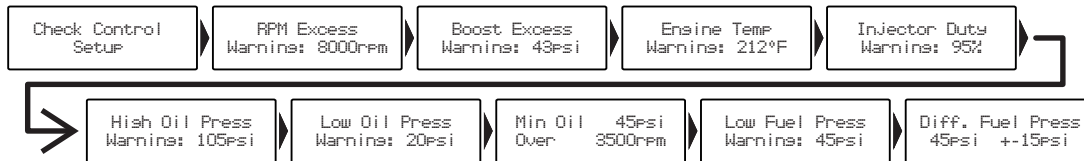
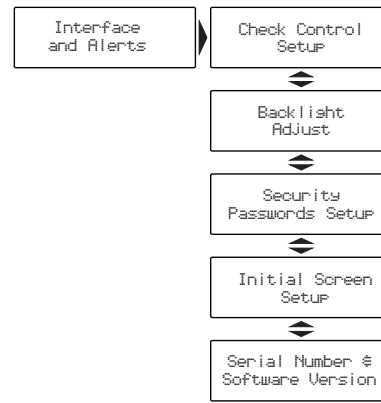

RPM Excess X RPM	High Oil Pressure X PSI
Pressure Excess X PSI	Low Oil Pressure x PSI
Engine Temperature Excess X °F	Low Fuel Pressure X PSI
Fuel injectors Opening % (it informs which Set has become saturate)	

The warning regarding real saturation of fuel injectors is configured by informing a percentage value of fuel injector real opening and it verifies both injector sets individually, indicating which one has exceeded the limit.

16.2 Backlight settings

When adjusting the liquid crystal display (LCD) backlight, the intensity of the light can be altered to Day Light Mode or Night Light Mode.

To select between the options, press and hold the up button for 2 seconds on the dashboard screen. This shortcut only works when the “Burnout Mode” function has been disabled.

The user can also modify the intensity of light for each mode. For that adjustment, enter the “Backlight Settings” option, at the “Interface and Alerts” menu.



16.3 Security passwords setup

Passwords can only be accessed and altered when the engine is turned off. Two types of passwords can be configured in the injection system:

User password

When activating the user password, it is possible to make 4 different

types of adjustments for blocking and protection purposes:

No protection: this option must be selected when the user wants to insert a password but keep free access to all menus. It must be chosen to avoid that any password is inserted without the user’s consent.

Protect menu only: with this option, all menus are protected against alterations. Open access is given only to read the information on the dashboard screen, and engine operation.

Block use only: this option blocks the engine start only. All menus are open for visualization and alteration, but the injection system is blocked until a password is inserted.

Protect menus and block injection: in this mode, engine start and the visualization and alteration of all injection parameters are blocked until a password is inserted.

When pressing the right button to enter the menu and a password has already been set, the system will request it to be inserted to open access. Use the up and down buttons to edit the characters, and the left and right buttons to move the prompt back and forth. Press the right button to confirm. The access is freed until injection is restarted or the password is disabled.

Tuner password

This password blocks the “Fuel Injection Tables Adjust”, “Ignition Tables Adjust”, “Aux Functions Adjust”, “Fuel Injection Setup”, “Ignition Setup” and the “Files Manager” menus, letting open access to the dashboard screen functions and configurations for Check Control, Shift Alert, Display and Initial Screen.

It is very useful when one wishes to protect only the main injection system functions, having all the additional functions available. When this password is active, it is not possible to alter any fuel injection or ignition table.

To access the menus blocked by the password, the tuner must press the right and hold the right button for 2 seconds, and then use the up and down buttons to edit the characters, and the left and right buttons to move the prompt back and forth. Press the right button to confirm. The access is freed until injection is restarted or the password is disabled.

To enable or disable the password, do as follows:

1. With no protection, press the right button. The "Fuel Injection Tables Adjust" menu will be displayed.
2. Press the down button to find the "Interface and Alerts" menu and press the right button to enter.
3. Press the down button until finding the "Security Passwords Setup" menu.
4. Enter the menu by pressing the right button. Press the down button to find the "Tuner Password" option.
5. Enter the "Tuner Password" menu by pressing the right button.

6. If a password has already been set, the system will request it to be inserted. If not, the system will move directly to the edition of a new tuner protection password.
7. Use the up and down buttons to edit the characters, and the left and right buttons to move the prompt back and forth. (To disable the protection, insert "0000").

16.4 Initial screen configuration

It is possible to customize the Initial Screen. When the injection system is turned on, the following screen is displayed indicating FuelTech Electronic Fuel Injection System model:

Soon after, the screen below is shown, and its standard text that can be customized according to the user's preferences:



16.5 Serial number and software version

In this menu, it is possible to verify the software version and the equipment's serial number.

Make sure to have these numbers in hand whenever the FuelTech Technical Support is contacted to facilitate and optimize the assistance.

17. Files manager – memory positions and functions

The Files Manager allows the user to alternate between the fuel injection maps saved in five memory positions, each one with different configurations and settings. Therefore, one could, for example, have five different settings for varied weather conditions or use. Another option is to use the same module for up to five different engines which may share the ECU but with their own adjustments and tunings saved. In that case, one or more extra cables may be requested.

Quick file change

When this function is active, through the dashboard screen, it is possible to make a quick change between settings with adjusted maps by pressing and holding the down button for two seconds.

Automatic calculation of fuel injection tables function

The function "Copy FuelTech Defaults" helps greatly when starting to tune a car, as it uses the data obtained from the "Fuel Injection Setup" to estimate a fuel map that will serve as a basis for the adjustments. Before using these functions it is very important that all the information and instructions given on **chapter 10 in this manual have been followed thoroughly.**

18. Full wiring diagram

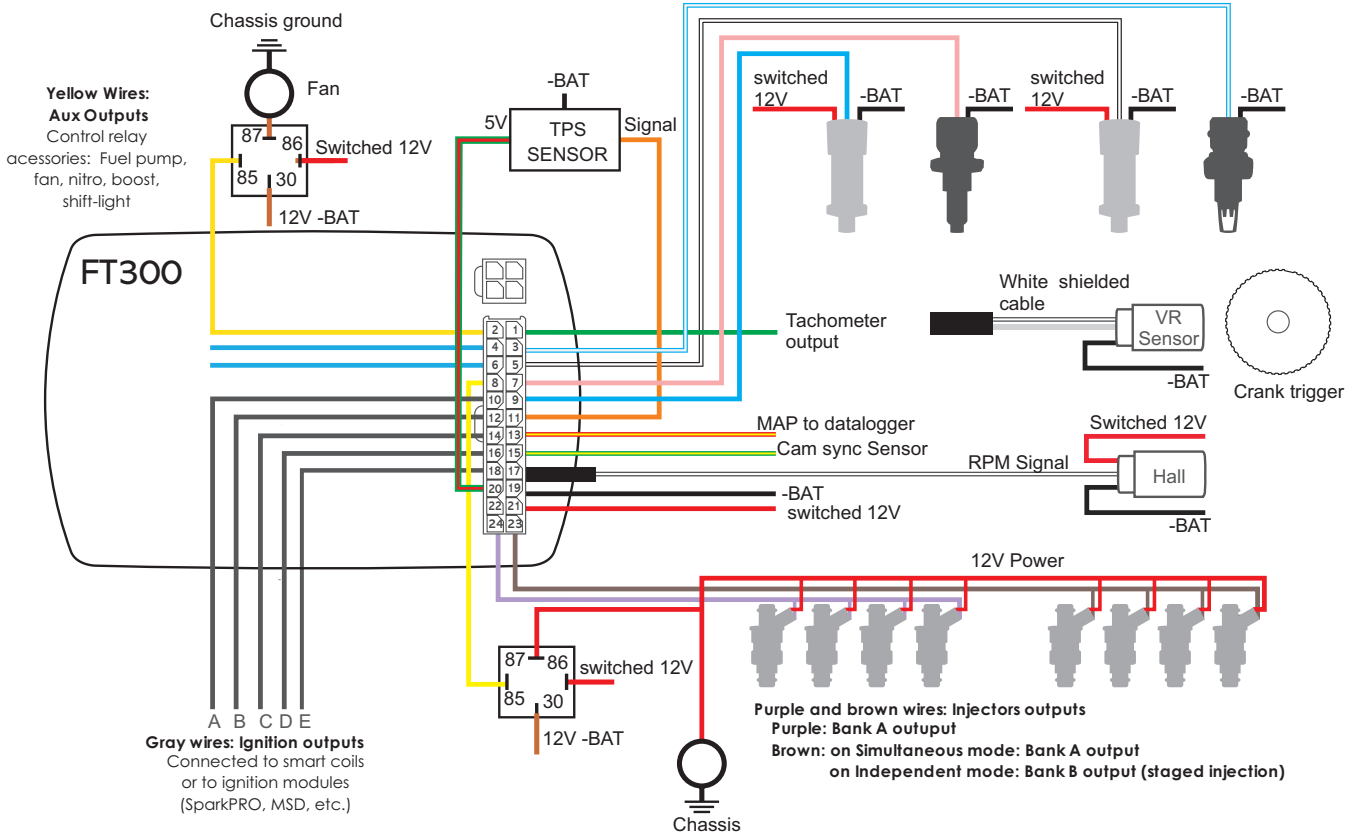
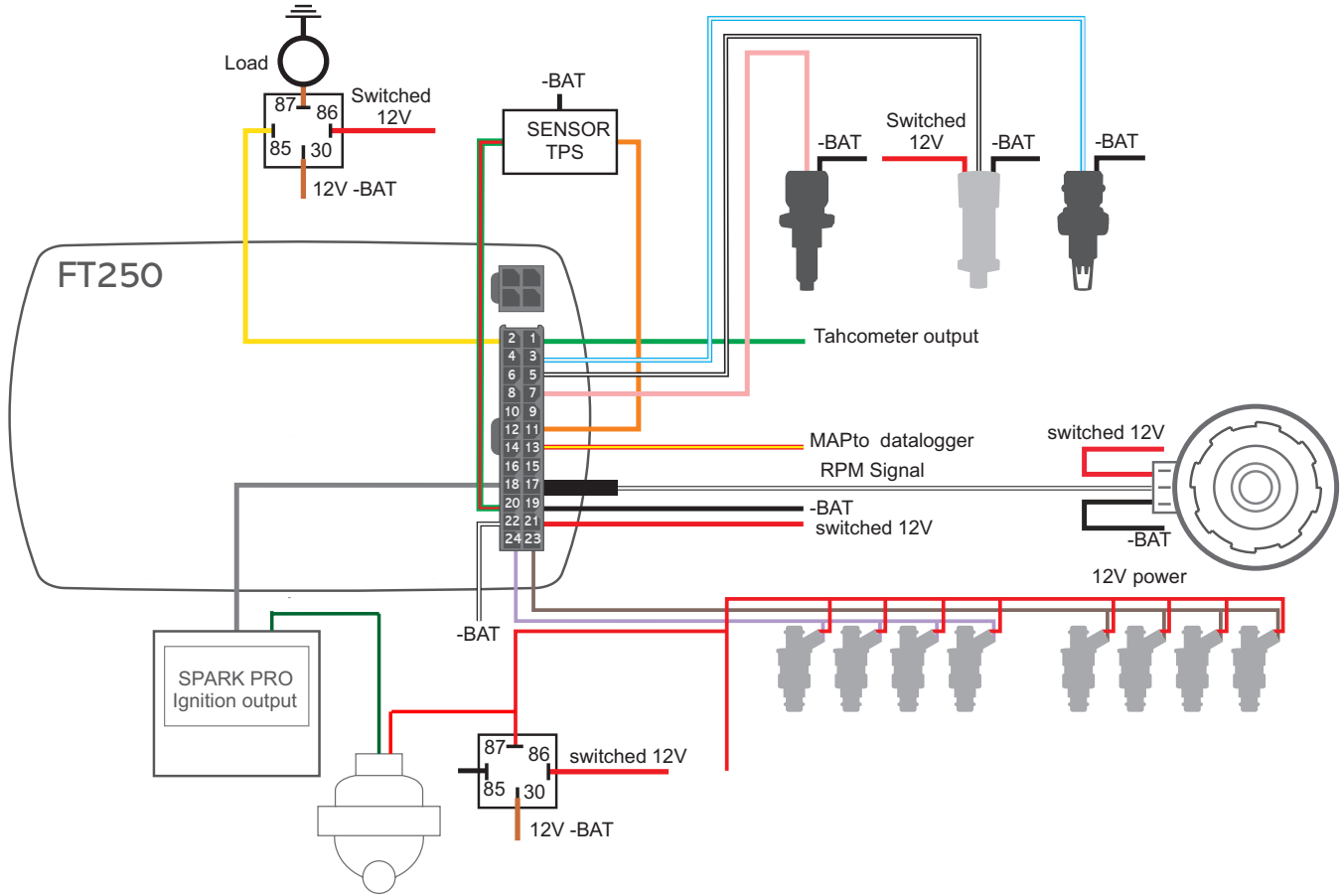

FuelTech

USA

455 Wilbanks Dr.
Ball Ground, GA, 30107, USA

Phone: +1 678-493-3835
Toll free: +1 855-595-3835
Email: info@fueltech.net
www.fueltech.net